

WEICHAI

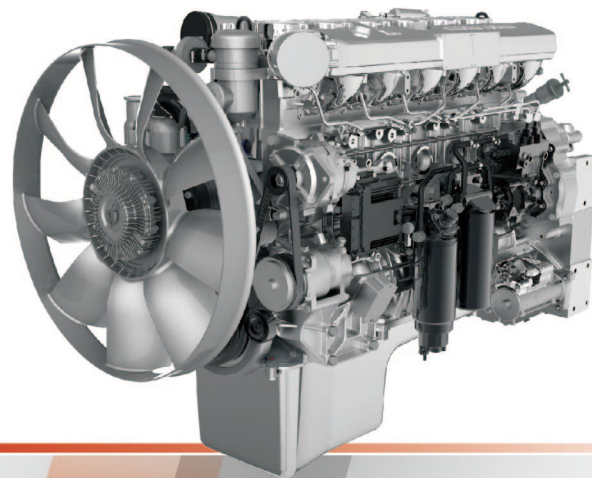

Weichai Official Website

Add:197A Fushou East Street,Weifang high-new technology
industrial development zone,Weifang,Shandong,China,
Tel:+86-536-8269988
Fax:+86-536-8232079
P.C:261000 China
E-mail:swiec@weichai.com
Website: www.weichai.com

WEICHAI
Truck Engine

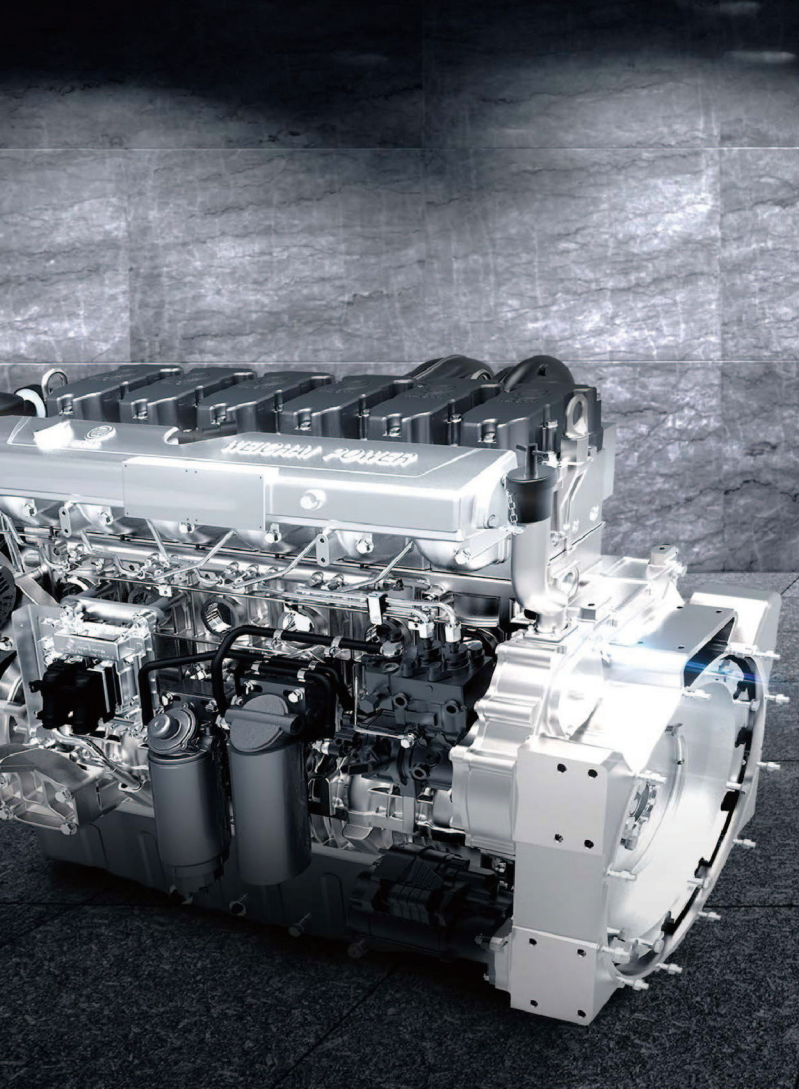

CONTENTS

About us	01
R&D capacity	02
Truck engine portfolios	03
Engine model list	05
Major product series	09
Weichai Service	17

ABOUT US



Introduction

Weichai has four business platforms covering power train, luxury yacht, vehicle and auto parts. Its subsidiaries are spread across Europe, North America, Southeast Asia and other regions. Global R&D and Operation Centers are established in Chicago, Marseilles, Forli, Frankfurt and Singapore. At present, Weichai has offices in more than 40 countries and over 400 authorized service stations. Weichai products has been sold to 100 countries and regions around the world. Weichai is committed to extending its industry supply chain and improving its competitiveness through strategic investments. Weichai acquired French Baudouin in 2009, further expanding engine business. In 2012, Weichai Group acquired 75 percent of Italy's Ferretti, the world's largest luxury yacht manufacturing enterprise. Later in 2012, Weichai Group's subsidiary, Weichai Power, signed a strategic cooperation agreement with KION Group, one of the world's top industrial forklift truck manufacturers and global leader of the hydraulic technology. Weichai aims to provide maximum satisfaction through its full range of engine and power offerings.

The most advanced manufacturing base of engines in the world

Weichai has an Industrial Park covering 220 hectares. Phase I invested 150 Million USD and 200,000 engines are produced per year. Phase II invested 140 Million USD and 150,000-ton castings are produced per year. All facilities are imported from world famous companies such as Heller of Germany, ATLAS and ABB of Switzerland. ALL facilities on the product line are connected by LAN, which manages production in realtime. The lines include 50 machining centers, 8 robots, 5 fine finishing centers and CMM.



R&D Capacity

Engines testing center development

Engines testing center at a cost of \$ 300 million to build, covers an area of 5,000 square meters, construction area of 10,000 square meters, is currently the largest, most versatile and the strongest engine test center.

- ①Germany TUV authorized laboratory
- ②China National Accreditation Service for Conformity Assessment (CNAS) authorized laboratory
- ③National key laboratory of internal combustion engine reliability



R&D Guarantee

Simulating Calculation	Five-axis test-bed	Vehicle hub rotation	Performance optimization
Provide theoretical support	Convenient and efficient matching test	Provide accurate test data	Promote power train performance

Three-height test team		
Qinghai-Tibet Plateau of 4000 meters altitude	82°C Dunhuang desert	-40°C Heihe snowfield

Team
30 people

Mission
To provide customers with a broad geographical adaptability, high-performance and high-quality products.

Truck engine portfolios

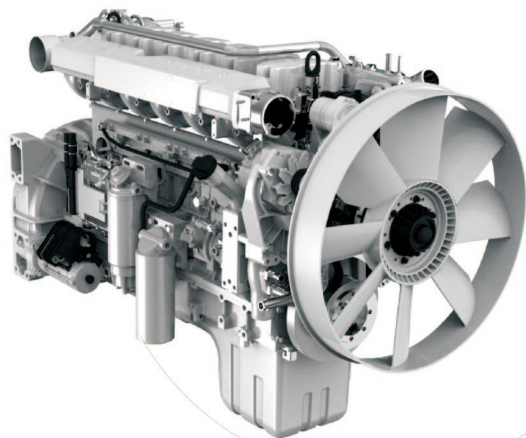

- Heavy-duty truck
- Medium-duty truck
- Light-duty truck
- Other application trucks



Euro V diesel engine for Heavy-duty /Medium-duty truck

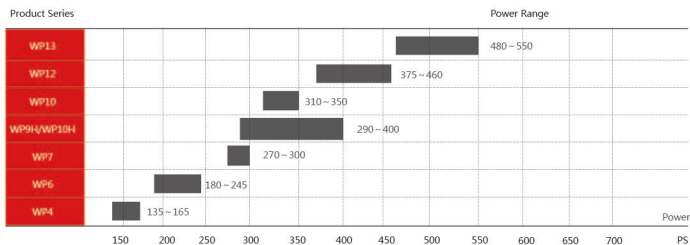

Technical route : Common rail +SCR

Euro V diesel engine for light-duty truck

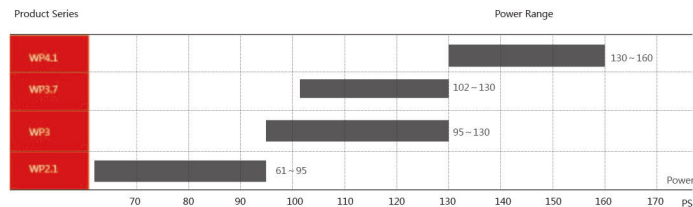

Technical route : Common rail +SCR

MODEL LIST

WP2.1/WP3/WP3.7/4.1/WP4/6/WP7/WP10/WP12/WP13 Model List for Truck Engine
Gas Engine Model List for Truck Engine

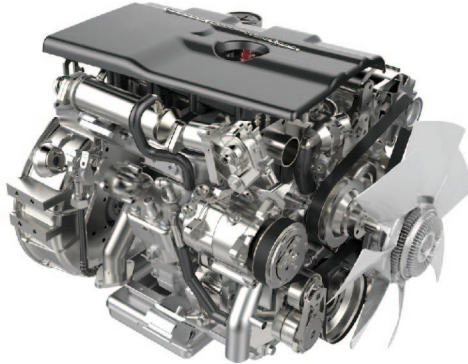

WP2.1 Model List

Series	Model	Emission	Displacement /cylinders	Per cylinder valve	Rated power/speed (kW/rpm)	Max.torque/speed (N.m/rpm)	Technical route
WP2.1	WP2.1Q61	Euro IV/V	2.1L/4	2	45/3200	165/1700 – 2300	Common rail+SCR
	WP2.1Q71				52/3200	185/1700 – 2300	
	WP2.1Q82				60/3200	215/1700 – 2300	
	WP2.1Q85				70/3200	245/1700 – 2300	

WP3 Model List

Series	Model	Emission	Displacement /cylinders	Per cylinder valve	Rated power/speed (kW/rpm)	Max.torque/speed (N.m/rpm)	Technical route
WP3	WP3Q110	Euro IV/V	2.97L/4	2	81/3000	310/1400 – 1800	Common rail+SCR
	WP3Q116				85/3000	340/1400 – 1800	
	WP3Q124				91/3000	350/1400 – 1800	
	WP3Q130				96/3000	350/1400 – 1800	

WP3.7/4.1 Model List

Series	Model	Emission	Displacement /cylinders	Per cylinder valve	Rated power/speed (kW/rpm)	Max.torque/speed (N.m/rpm)	Technical route
WP3.7	WP3.7Q102	Euro IV/V	3.7L/4	2	75/2900	285/1400 – 1800	Common rail+SCR
	WP3.7Q113				83/2900	320/1400 – 1800	
	WP3.7Q130				96/2900	380/1400 – 1800	
WP4.1	WP4.1Q130	Euro IV/V	4.1L/4	2	97/2600	420/1200 – 1800	Common rail+SCR
	WP4.1Q140				103/2600	450/1200 – 1800	
	WP4.1Q150				110/2600	500/1200 – 1800	
	WP4.1Q160				115/2600	520/1200 – 1800	

WP4/6 Model List

Series	Model	Emission	Displacement /cylinders	Per cylinder valve	Rated power/speed (kW/rpm)	Max.torque/speed (N.m/rpm)	Technical route
WP4	WP4.135	Euro II	4.5L/4	2	100/2300	500/1400 – 1600	Mechanical pump+ EGR
	WP4.150				110/2300	550/1400 – 1600	
	WP4.165				121/2300	600/1400 – 1600	
	WP4.135				100/2300	500/1200-1600	
	WP4.150	110/2300	550/1200-1600				
	WP4.165	121/2300	600/1400 – 1600				
	WP4.135	100/2300	500/1200-1600	Common rail+SCR			
	WP4.150	110/2300	550/1200-1600				
WP4.165	121/2300	600/1400 – 1600					
WP4.135	100/2300	500/1200-1600	Mechanical pump+ EGR				
WP6.210	Euro II	6.75L/4		2	155/2300	800/1400 – 1600	
WP6.240					176/2300	900/1400 – 1600	
WP6.180					132/2300	650/1400 – 1600	
WP6.210			155/2300		800/1400 – 1600	Common rail	
WP6.240	176/2300	900/1400 – 1600					
WP6.160	118/2300	610/1200-1700	Common rail+SCR				
WP6.180	132/2300	680/1400-1600					
WP6.200	147/2300	750/1400-1600					
WP6.220	162/2300	850/1400-1600					
WP6.245					180/2300	900/1100-1700	

WP7 Model List

Series	Model	Emission	Displacement /cylinders	Per cylinder valve	Rated power/speed (kW/rpm)	Max.torque/speed (N.m/rpm)	Technical route
WP7	WP7.210	Euro II	7.5L/6	4	155/2300	950/1400 – 1600	Mechanical pump+ EGR
	WP7.240				176/2300	1050/1400 – 1600	
	WP7.270				199/2300	1160/1400 – 1600	
	WP7.300				220/2300	1160/1400 – 1600	
	WP7.210				155/2300	900/1200 – 1600	
	WP7.240	176/2300	1000/1200 – 1600				
	WP7.270	199/2300	1100/1200 – 1600				
	WP7.300	220/2300	1160/1200 – 1600				
	WP7.270	199/2300	1160/1200-1500	Common rail+SCR			
	WP7.300	220/2300	1250/1200-1500				

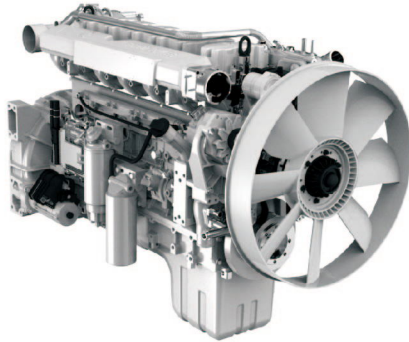

WP10 Model List

Series	Model	Emission	Displacement /cylinders	Per cylinder valve	Rated power/speed (kW/rpm)	Max.torque/speed (Nm/rpm)	Technical route
WP10	WP10.270	Euro II	9.7L/6	2	199/2200	1100/1200-1600	Mechanical pump+EGR
	WP10.290				213/2200	1160/1200-1600	
	WP10.310				228/2200	1250/1200-1600	
	WP10.340				250/2200	1350/1200-1600	
	WP10.380				280/2200	1460/1200-1600	
	WP10.270N				199/1900	1270/1200-1500	
	WP10.290N				213/1900	1340/1200-1500	
	WP10.310N				228/1900	1420/1200-1500	
	WP10.340N				250/1900	1500/1200-1500	
	WP10.270				199/2200	1100/1200-1600	
	WP10.290	213/2200	1160/1200-1600				
	WP10.310	228/2200	1180/1200-1600				
	WP10.336	247/2200	1250/1200-1600				
	WP10.336	276/2200	1460/1200-1600				
	WP10.375	276/2200	1650/1200-1600				
	WP10.270N	199/1900	1270/1200-1500				
	WP10.300N	221/1900	1390/1200-1500	Common rail+SCR			
WP10.336N	247/1900	1500/1200-1500					
WP10.310	228/2200	1420/1200-1500					
WP10.336	247/2200	1500/1200-1500					
WP10.350	257/2200	1550/1200-1600					
WP10.270	199/1900	1340/1200-1500					
WP10.290	213/1900	1420/1200-1500					
WP10.310	228/1900	1500/1200-1500					
WP10.336	247/1900	1550/1200-1500					
WP10.350	257/1900	1600/1200-1600					

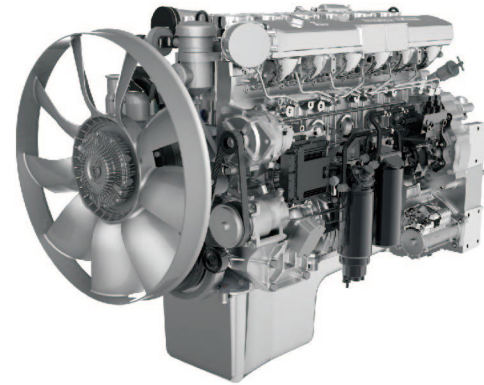

WP12 Model List

Series	Model	Emission	Displacement /cylinders	Per cylinder valve	Rated power/speed (kW/rpm)	Max.torque/speed (Nm/rpm)	Technical route
WP12	WP12.340	Euro II	11.6L/6	2	250/2200	1400/1300-1400	Mechanical pump+EGR
	WP12.380				280/2200	1500/1300-1400	
	WP12.400				294/2200	1600/1300-1400	
	WP12.420				309/2200	1750/1300-1400	
	WP12.380N				280/1900	1700/1200-1400	
	WP12.336N				247/1900	1600/1000-1400	
	WP12.375N				276/1900	1800/1000-1400	
	WP12.400N				294/1900	1920/1000-1400	
	WP12.430N				316/1900	2060/1000-1400	
	WP12.460N				338/1900	2110/1000-1400	
WP12.480	353/2100	1970/1200-1500					
WP12.336	247/1900	1615/1000-1400					
WP12.375	276/1900	1800/1000-1400					
WP12.400	294/1900	1920/1000-1400					
WP12.430	316/1900	2060/1000-1400					
WP12.460	338/1900	2110/1000-1400					

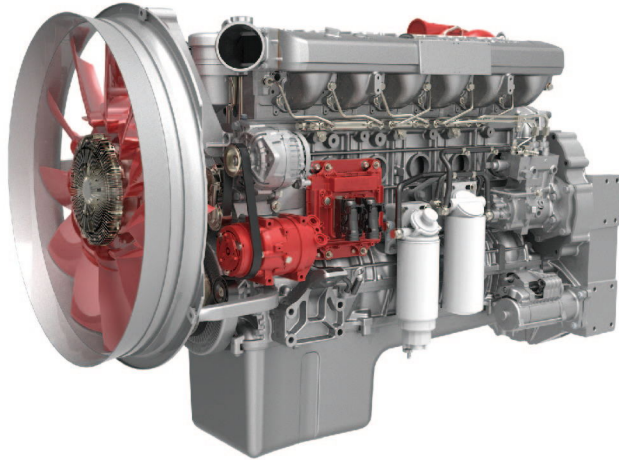

WP13 Model List

Series	Model	Emission	Displacement /cylinders	Per cylinder valve	Rated power/speed (kW/rpm)	Max.torque/speed (N.m/rpm)	Technical route
WP13	WP13.480	Euro IV	12.54L/6	4	353/1900	2400/950-1400	Common rail+SCR
	WP13.480				353/1900	2300/1000-1300	
	WP13.500	Euro V			368/1900	2400/1000-1300	
	WP13.530				390/1900	2500/1000-1300	
	WP13.550				405/1900	2550/1000-1300	

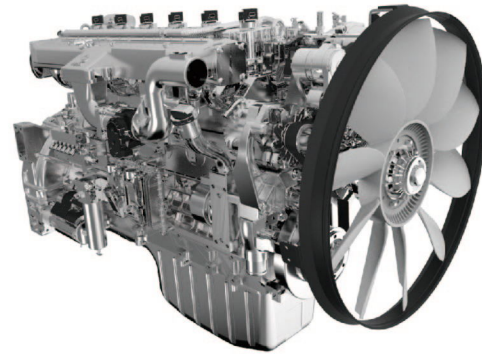

Gas Engine Model List

Series	Model	Emission	Displacement /cylinders	Per cylinder valve	Rated power/speed (kW/rpm)	Max.torque/speed (N.m/rpm)	Technical route
WP4.1NG	WP4.1NG100	Euro IV/V	4.1L/4	2	74/2600	350/1200-1800	Single point injection + oxidation catalysis
	WP4.1NG125				92/2600	400/1200-1800	
	WP4.1NG140				103/2600	450/1200-1800	
	WP4.1NG150				110/2600	500/1300-1800	
WP6NG	WP6NG210	Euro IV/V	6.75L/6	2	155/2300	720/1400-1600	Single point injection + oxidation catalysis
	WP6NG240				176/2300	780/1400-1600	
	WP7NG240				177/2100	900/1300-1500	
WP7NG	WP7NG260	Euro IV/V	7.47L/6	4	191/2100	1000/1300-1500	Single point injection + oxidation catalysis
	WP7NG270				199/2100	1050/1300-1500	
	WP7NG280				206/2100	1150/1300-1500	
	WP10NG260				191/1900	1200/1200-1500	
	WP10NG280				206/1900	1300/1200-1500	
WP10NG	WP10NG300	Euro IV/V	9.726L/6	4	220/1900	1400/1200-1500	Single point injection + oxidation catalysis
	WP10NG336				247/1900	1450/1200-1500	
	WP12NG350				257/1900	1700/1200-1500	
WP12NG	WP12NG380	Euro IV/V	11.596L/6	4	280/1900	1700/1200-1500	Single point injection + oxidation catalysis
	WP12NG400				284/1900	1730/1200-1500	
WP13NG	WP13NG410	Euro IV/V	12.54L/6	4	301/1900	1750/1100-1400	Single point injection + oxidation catalysis
	WP13NG430				316/1900	1800/1100-1400	

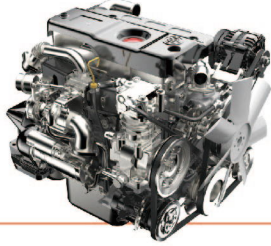

Major Engine Products for truck

WP2.1 Engine Model

As an innovative model on the light-engine market, WP2.1 has been designed and developed by Weichai based on its over 6 decades of proven philosophy in product development.

Specifications

Economy: The model boasts a min. SFC of 207g/kWh, in addition to a range of economic speed of 1,300-2,600 rpm, which is wider than that of any competitor.

Dynamic performance: Much higher torque at low speed significantly improves the starting and acceleration of vehicles. Max. torque of up to 245Nm better satisfies the needs of grade climbing and acceleration for overtaking.

SPEC SHEET

Project	Type	Disp (L)	Bore/Stroke (mm)	Rated power (PS)	Rated speed (rpm)
WP2.1	In-line, Turbo-charged and intercooled, CR and SCR	2.1	85×92	61-95	3200

Outline - WP2.1

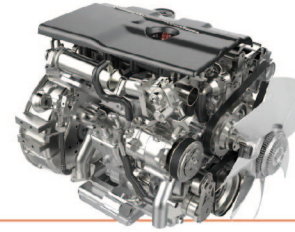
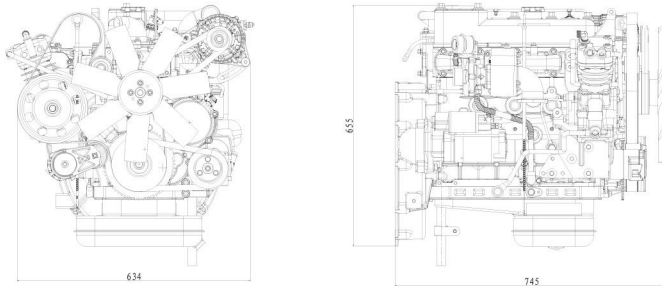

WP3 Engine Model

WP3 is Weichai's high-end Euro V-compliant model recently launched to meet the new market environment. As the outcome of four years of development, it is based on integration of worldwide resources and a VM product introduced from Europe. The engine is suitable to high-end light trucks of mainstream makes, with the wheel base of 2.8m - 3.8m and wide, medium, and narrow bodies.

Specifications

Economy: The standard configuration includes a silicon oil fan that saves oil by 3% as compared to a rigid one. The L/100km fuel consumption is 1L less than that of competitors.

Dynamic performance: A 13%-increase in low-speed torque provides more powerful starting and acceleration. Max. torque is 14% higher than comparably powerful competitors, resulting in enhanced gradeability and overloading capacity.

Reliability: The model has undergone strict tests and assessments on stands, under high and low temperature, on high altitude, and over revolving drums. All its mission-critical components are proven to be highly reliable, with the B10 life as high as up to 800,000km.

NVH: With a high torque at low speed, the engine normally runs at lower speeds than those of its competitors. This avoids its range of high-frequency torsional oscillation and reduces its noise by 2dB. The NVH performance is better than that of its competitors, and the noise emitted during acceleration is 4dB (A) lower than that of its competitors.

SPEC SHEET

Project	Type	Disp (L)	Bore/Stroke (mm)	Rated power (PS)	Rated speed (rpm)
WP3	In-line, Turbo-charged and intercooled, CR and SCR	3L	94×107	95-131	3000

Outline - WP3

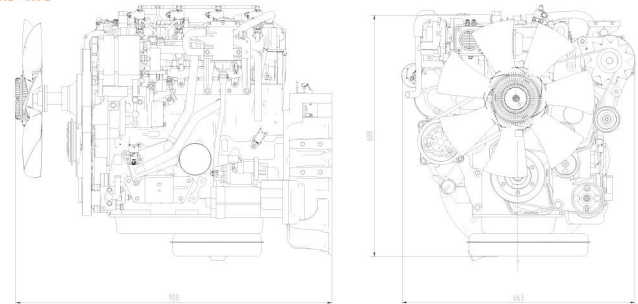



WP3.7/4.1 Engine Model

WP3.7/WP4.1 light engines have been developed with the outstanding resources consisting of platform R&D, power train, NVH and application engineering teams at Weichai's head office.

Specifications

Excellent economy: The min. SFC is as low as 205g/kWh and the fuel-saving range is extended to 1,100 - 2,400 RPM.

Dynamic performance: Extremely strong gradeability and overtaking capacity - For example, WP3.7 has the max. torque of 400 N·m, representing a torque reserve of up to 27%; Robust starting and acceleration - An optimized turbo charger provides large torque at low speed, or 350N·m@1,000 RPM.

NVH: A reinforced cylinder block of a gantry form and additional reinforcing plates for the engine body provide higher strength, reducing the noise by 0.7dB and vibration intensity by 10%. Helical gears of Grade 7 precision enables more accurate engagement, additionally decreasing the noise by 0.5dB.

SPEC SHEET

Project	Type	Disp (L)	Bore/Stroke (mm)	Rated power (PS)	Rated speed (rpm)
WP3.7	In-line, Turbo-charged and intercooled, CR and SCR	3.7	102×112	102-131	2900
WP4.1		4.1	105×118	132-156	2600

Outline - WP3.7/4.1

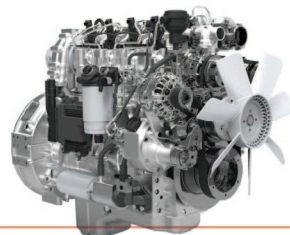
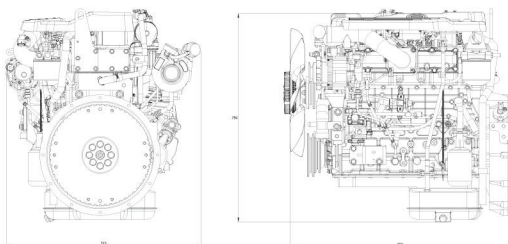

WP4/6 Engine Model

WP4/6 is a Euro V-compliant series developed by Weichai based on Deutz 226B using Bosch's high-pressure common rail system.

Specifications

Economy: A switch system for idle speed adjustment ensures low fuel consumption while maintaining dynamic performance.

Dynamic performance: The model features high torque at low speed, and max. torque of 600N·m for WP4 and 900 N·m for WP6. All these guarantee their excellent starting and acceleration performance.

Structure: The front end of engine can cater for single or dual dynamo in the arrangement structure.

SPEC SHEET

Project	Type	Disp (L)	Bore/Stroke (mm)	Rated power (PS)	Rated speed (rpm)
WP4	In-line, Turbo-charged and intercooled, CR and SCR	4.5	105/130	136-165	2300
WP6		6.75	105/130	180-271	2300

Outline - WP4/6

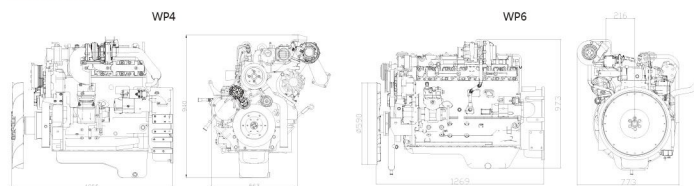

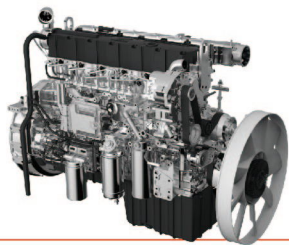

WP7 Engine Model

WP7 engines are Euro VI-certified products used to power high-end trucks of medium to heavy duty. They have been jointly developed by Weichai, AVL, and Bosch. WP7 Super Edition boasts higher engine torque. The major products are of 270 HP and 300 HP, which are ideal drive for 8x4 trucks and road dumpers of lightweight designs. These engines provide competitive edge on technical specifications, strengthening, and design quality.

Specifications

Economy: The engine boasts a min. SFC of 195g/kWh and economic speed range of 1,200 - 1,800 RPM. If vehicle arrangement is adjusted to use rear axles of low gear ratio, WP7/WPS can have a comprehensive oil consumption that is apparently better than that of competitors of the comparable dynamic performance.

Dynamic performance: Low speed and high torque provide significantly advantageous dynamic performance over peers in terms of gradeability and acceleration.

Adaptability: The front-end of engine can cater for single, dual, or triple dynamo and structure support for A/C to meet vehicle needs.

SPEC SHEET

Project	Type	Disp (L)	Bore/Stroke (mm)	Rated power (PS)	Rated speed (rpm)
WP7	In-line, turbo charging and inter-cooling, CR and SCR	7.5	108/136	211-299	2300

Outline - WP7

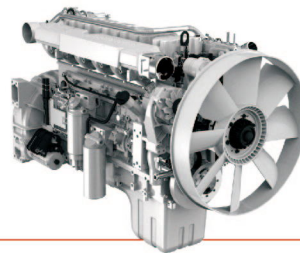
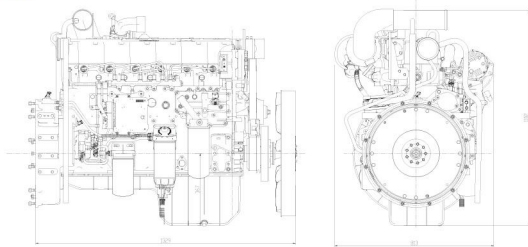

WP10 Engine Model

WP10 inherits the robustness, durability and power of Weichai engines. It is the golden drive of dumpers, trucks, and tractors.

Specifications

Economy: Min. fuel economy is 3g-10g lower than that of competitors as a minimum. The range of economic fuel consumption is wide. The fuel economy of vehicles can be increased by 3-5%.

Dynamic performance: Large displacement and torque reduce gear-shifting frequency by 22% over competing vehicles of the same configuration under the same road conditions, and enable grade-climbing at one gear position higher than the competitors.

This reduces fuel consumption and improves driving comfort. More sufficient reserve of torque makes it easier to overtake and improves transport efficiency.

Product SPEC SHEET

Project	Type	Disp (L)	Bore/Stroke (mm)	Rated power (PS)	Rated speed (rpm)
WP10	In-line, turbo charging and inter-cooling, CR and SCR	9.726	126/130	271-375	1900, 2200

Outline - WP10

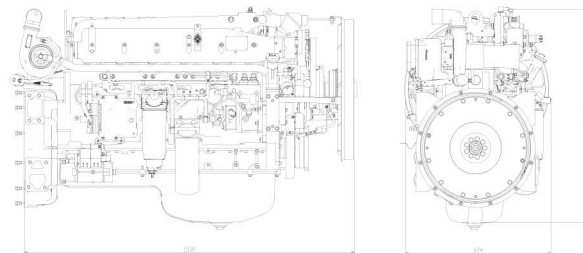

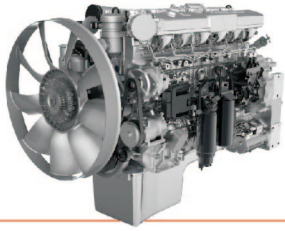

WP12/13 Engine Model

WP12/13 is jointly developed by Weichai's European R&D Centre, AVL, and Bosch and provides world-leading performance.

Specifications

Economy: High-pressure common rail technology reduces fuel consumption, emission, and noise. Low rated speed (1,900 RPM) helps minimize friction and improve reliability, and provides comfort and lower noise.

Dynamic performance: These are powerful engines with low speed and high torque.

SPEC SHEET

Project	Type	Disp (L)	Bore/Stroke (mm)	Rated power (PS)	Rated speed (rpm)
WP12	In-line, Turbo-charged and intercooled, CR and SCR	11.596	126/155	375-460	1900, 2100, 2200
WP13		12.54	127/165	480-550	1900-2100

Outline - WP12/13

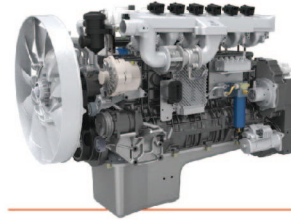
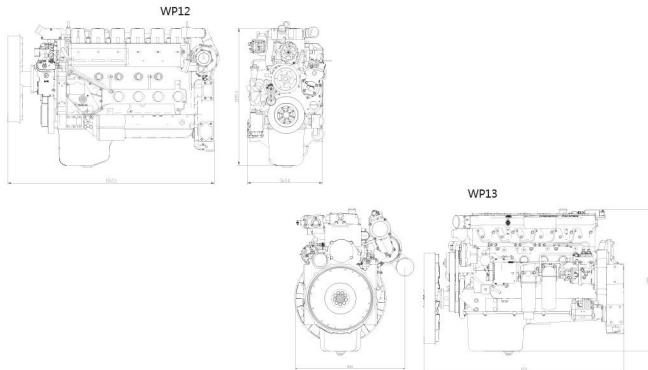

WP12NG Engine Model

WP12 gas engines incorporate a four-valve structure to take in more fresh air more smoothly. Centrally positioned spark plugs provide shorter and faster combustion, thereby improving the economy and elevating the dynamic performance of the engines by 10-15%.

Specifications

Economy: New mixers are designed and matched to increase the mixing uniformity, thereby improving combustion in cylinders.

Dynamic performance: Max. torque is increased to 1,730Nm. A four-valve structure enables the engines to take in more fresh air more smoothly. Centrally positioned spark plugs provide shorter and faster combustion. This improves the economy and elevates the dynamic performance of the engine by 10-15%.

Reliability: The four-valve gas engine series inherits the body of Weichai diesel engines. A structure featuring increased water pump flow provides better cooling performance, reducing the thermal load of engines and improving the reliability.

SPEC SHEET

Project	Type	Disp (L)	Bore/Stroke (mm)	Rated power (PS)	Rated speed (rpm)
WP12NG	In-line, Turbo-charged and intercooled	11.596	126/155	350-400	1900

Outline - WP12NG

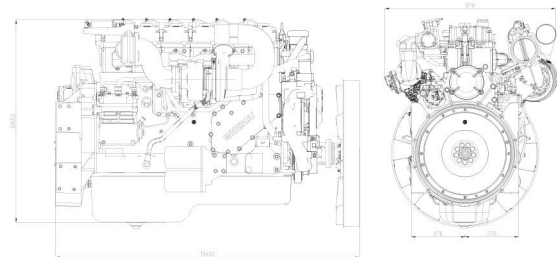

Weichai Service

Products of Weichai Power have been sold to 100 countries and regions on five continents. Currently, a worldwide service network had been established with 40 foreign field offices and over 400 authorized service locations.

Also, Weichai has set up global operation centers in Wiesbaden/ Aschaffenburg (Germany), Forlì (Italy), Marseilles (France), Chicago(USA), and Singapore, etc.

