

Driver's Handbook

Addendum

Addendum, Mack Trucks (Release Date
February 2015)



Foreword

The information in this manual applies to vehicles built January 2011 and later. Please keep this addendum in the vehicle at all times.

The National Highway Traffic Safety Administration (NHTSA) and MACK Trucks should be informed immediately if you believe that the vehicle has a defect that could cause a crash, injury or death.

Contact NHTSA by calling the Auto Safety Hotline at 1 (888) 327-4236, by writing to NHTSA, U.S. Department of Transportation, Washington, DC 20590, by TTY at 1 (800) 424-9153, or visit their website at www.nhtsa.dot.gov.

Mack Trucks

Greensboro, NC USA

Order number: PV776-22616311

©2015 Mack Trucks Greensboro, NC USA

All rights reserved. No part of this publication may be reproduced, stored in retrieval system, or transmitted in any forms by any means, electronic, mechanical, photocopying, recording or otherwise, without the prior written permission of Mack Trucks

Contents

Addendum	1
Automatic Traction Control (ATC) (If Equipped)	1
Towing Information	2
Towing a Vehicle Equipped with mDRIVE Transmission	2
Towing	6
Lifting The Front Suspension	6
ABS	7
Lifting The Rear Suspension	7
Unloading.....	7
Max. Loading During Lifting and Towing	8
Lifting, General.....	9
Lifting A Vehicle With Leaf Springs	9
Lifting A Vehicle With Air Suspension	10
Towing Configurations (Rear, Side, and Using the Tow Hooks).....	15
Parking Brakes and Towing Hooks.....	15
Towing Backwards And Sideways	17
Towing Backwards.....	17
Towing Sideways	17
Releasing The Brake.....	18
Parking Brake — Mechanical Release	18
Disk Brakes.....	19
Brakes In Winter	19
Jump Starting	20
Engine Components, Service Schedules.....	22
MP7, MP8 and MP10 (US2010 and Newer) Engine Oil Change Intervals.....	22
MP7, MP8 and MP10 Engines	22
Engine Intake Air Cleaner	26
Engine Component Maintenance Intervals.....	27
Engine Coolant.....	27
Drive Belts (Fan and Accessory)	29
Engine Valve Adjustments.....	30
Exhaust Aftertreatment System	31
Rear Axle Oil Change Intervals.....	32
T300 Series Manual Transmission Oil Change Interval	34
mDRIVE Transmission Oil Change Intervals	36
Power Steering Fluid.....	38

Safety Information

IMPORTANT: Before driving this vehicle, be certain that you have read and that you fully understand each and every step of the driving and handling information in this manual. Be certain that you fully understand and follow all safety warnings.

IT IS IMPORTANT THAT THE FOLLOWING INFORMATION BE READ, UNDERSTOOD AND ALWAYS FOLLOWED.

The following types of advisories are used throughout this manual:



DANGER

Danger indicates an unsafe practice that could result in serious personal injury or death. A danger advisory banner is in **white** type on a **black** background with a **black** border.



WARNING

Warning indicates an unsafe practice that could result in personal injury. A warning advisory banner is in **black** type on a **gray** background with a **black** border.



CAUTION

Caution indicates an unsafe practice that could result in damage to the product. A caution advisory is in **black** type on a **white** background with a **black** border.

Note: Note indicates a procedure, practice, or condition that must be followed in order for the vehicle or component to function in the manner intended.

Automatic Traction Control (ATC) (If Equipped)

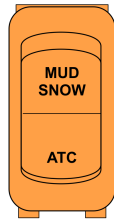

W3089687

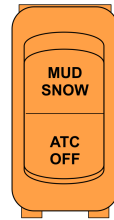

W3089688

ATC Functionally

Automatic Traction Control (ATC) provides improved traction on slippery surfaces by reducing wheel spin. If a drive wheel starts to spin the system operates automatically as follows:

ATC applies air pressure to the brake of the spinning wheel. Doing this transfers engine torque via the axle differential to the wheels that have better traction. Brake control is active at vehicle speed up to 25 MPH.

ATC limits engine torque which, in turn, reduces wheel spin to provide improved traction. The driver may override torque control by further pressing the accelerator pedal. Engine torque is active at all vehicle speeds.

When ATC automatically becomes active, the ATC indicator lamp turns on to alert the operator. The lamp turns off when the wheel(s) stops spinning.

ATC OFF (If Equipped)

ATC may also include the “ATC OFF” option that is selectable to the driver via the ATC OFF switch which is located on the dashboard.

When this function is activated with the ATC OFF mode switch which is located on the dashboard, the ATC OFF function will turn off the Automatic Traction Control (ATC) by allowing torque to be applied to all drive wheel as required by the driver and will not reduce wheel spin by applying the brakes or reducing engine torque.

When the operator selects the heavy ATC OFF function, the ATC indicator lamp be on continuously to indicate that the Automatic Traction Control (ATC) is not available. The ATC lamp will turn off when the ATC OFF mode switch is turned off.

Heavy Mud/Snow Function (If Equipped)

ATC may also include a heavy mud/snow function which allows the operator to activate ATC when additional traction is needed.

When this function is activated, with the ATC MUD/SNOW mode switch which is located on the dashboard, the heavy mud/snow function increases available traction by increasing permissible wheel spin.

When the operator selects the heavy mud/snow function, the ATC indicator lamp blinks continuously.

The ATC lamp stops blinking when the ATC mode switch is turned off.

Towing Information

Towing a Vehicle Equipped with mDRIVE Transmission

Vehicles Equipped with AMT-D (mDRIVE) without Towing Alternative Procedure

Note: Refer to label on the driver door to check if vehicle is equipped with Towing Alternative Procedure.

 **CAUTION**

Severe Transmission Damage When Towed

Unless the vehicle is moved under its own power, the axles or driveshaft must be removed or drive axle must be off the ground. If for any reason this procedure cannot be applied, refer to driver manual to check how to use towing alternative procedure.

W4093877

If the vehicle is not equipped with the Towing Alternative Procedure, the driveshaft must be disconnected to tow the vehicle.



CAUTION

Failure to disconnect the drive axle shaft(s) or lift the drive wheels off the ground before towing or pushing the vehicle can cause serious transmission damage.



DANGER

If the driveshaft has been disconnected for towing, **DO NOT** reuse bearing retainer bolts or stamped strap bolts, or stamped straps. Reuse of bearing retainer bolts or stamped strap bolts, or stamped straps can cause driveline failure, which can result in separation of the driveline from the vehicle. A separated driveline can result in property damage, serious personal injury or death.

4 Addendum

Vehicles Equipped with AMT-D (mDRIVE) and with Towing Alternative Procedure

Note: This procedure is not intended to replace the standard towing procedures and must only be used when it is not possible to follow the standard procedures.

If the vehicle cannot have the driveshaft removed and is equipped with Towing Alternative Procedure, the vehicle can be towed without the removal of the driveshaft. This procedure allows the vehicle to be removed from toll-ways, bridges, and tunnels without disconnecting the driveshaft.



CAUTION

At the earliest possible time, the vehicle should be configured for standard towing by disconnecting the axle shaft. Failure to disconnect the drive axle shaft(s) or lift the drive wheels off the ground before towing or pushing the vehicle can cause serious transmission damage.

Note: Refer to label on the driver door to check if vehicle is equipped with towing alternative procedure. Also, some vehicles have had the transmission control module (TCM) software updated to add the towing alternative procedure.

When the Towing Alternative Procedure is used, 3rd gear and High Range is engaged which enables the oil pump to rotate during towing. Towing gear 3 HR will be engaged if the following conditions are met:

- Transmission in neutral position
- Vehicle moves forward faster than a set limit for a number of seconds
- Engine is not running
- Air pressure to the transmission must be greater than 700 kPa (100 psi). Air should be supplied continuously from the towing vehicle.
- Ignition ON and power provided to the TCM
- Battery voltage must be 12 volts or higher for proper TCM function
- No transmission air pressure diagnostic trouble codes (DTC)



CAUTION

Reverse towing is not allowed when Towing Alternative Procedure is used. Reverse towing can damage the transmission.



CAUTION

Do not use the Towing Alternative Procedure if the vehicle has been in an accident that has compromised the oil cooling lines or cooler or if the vehicle is being towed for transmission failure. Using this procedure may result in further damage to the equipment.

This procedure should NOT be used in the following situations.

- Vehicle power and or air supply cannot be verified to the transmission or cannot be consistently supplied from the towing vehicle if moving longer distances.
- Heavy frontal damage to the radiator assembly on vehicles that have the transmission oil cooler in the bottom tank of the radiator, and the cooler lines are compromised. Towing with broken lines will pump all the oil out of the transmission and further damage the equipment.
- Complaints involving transmission failure that requires towing.
- Active air pressure DTC in the Instrument Cluster for the transmission.

6 Addendum

Towing

Note: During towing, the main switch and parking lamps shall be lit if the electrical system of the vehicle is functioning.

Lifting The Front Suspension

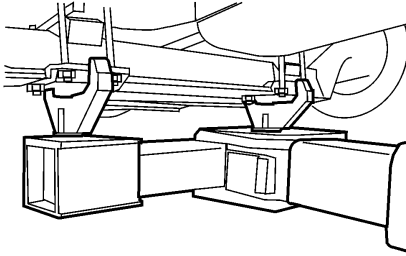

W7001301

Note: When the vehicle is towed with the front suspension lifted, the steering lock must be released.



CAUTION

When the driving wheels are still in contact with the ground the axle drive shaft must always be removed in order not to damage the gearbox.

If the half shafts have to be removed, if the rear axle has been damaged for example, the hubs must always be provided with close fitting covers. Sand and dirt could otherwise find their way in and cause considerable damage.

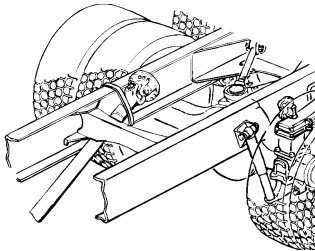

T0006670

Disconnect the propeller shaft from the rear axle and fix it securely to the chassis, or remove the entire propeller shaft.

ABS

Note: During towing with the front suspension lifted, a fault code for “abnormal sensor signal front” is set in the ABS system. This should be considered during the next service, when the ABS fault codes are checked.

The fault code is deleted with the service tool, please refer to the service information for the ABS system.

Lifting The Rear Suspension

Note: When the vehicle is towed with the rear suspension lifted, the steering wheel must be locked with the steering lock, or lashed.

Method: This method is preferred when the proper equipment is not available to perform the wheel lift method and is necessary for wreckers not equipped with an under lift system.

Unloading

Always unload the vehicle before lifting the rear suspension, if circumstances allow it.

The vehicle is unloaded to reduce the axle loading on the towing vehicle, limit the loading on the vehicle's lifting points and minimize the risk of damage to the load which could occur during towing.

If it is not possible to unload the vehicle where it is, it can be towed a short distance to a suitable place where unloading can take place.

8 Addendum

Max. Loading During Lifting and Towing

This table specifies the loading which can be applied to the towing hook, towing hitch cross-member, axles and torque stay anchorages.

Single Towing Hook	Double Towing Hooks	Towing Hitch, Towing Hitch Cross-Member ¹	Axles, Front And Rear	Air Suspension Vehicles, Front Torque Stays
The hook must not be loaded by more than the vehicle's gross weight.	Each hook must not be loaded by more than the vehicle's gross weight.	Lengthways: 20 tons	Static loading, lengthways and vertically: 2 x axle loading	Per side: max. 5 tons
		Vertically (lift): 7 tons	Dynamic, e.g. during towing:	Gross:
Note: The towing hooks on the vehicle must only be used for towing.		Sideways: 17 tons	1 x axle loading	max. 9.5 tons

¹ max. 200 mm (7.8 inches) from center of member web

Lifting, General

Vehicles must only be lifted by the lifting points specified below. Always use suitable lifting devices, such as clevises and chassis guards, to avoid damaging the vehicle.

Lifting A Vehicle With Leaf Springs

See also “Max. Loading During Lifting and Towing”, page 8 .

Front Suspension

Lift behind the front spring anchorage on the chassis member, or beneath the front axle.

Twin Front Axles

Lift beneath the forwards front axle, as above.

Note that on vehicles with twin front axles, a greater lift height is needed to get the wheels on the rearwards front axle to lift from the ground.

The wheels on the front axles can be removed to reduce the lift height.

Rear Suspension

Lift underneath the towing hitch cross member in the first instance. If the vehicle does not have a towing hitch cross member, use the chassis ends for lifting.

**CAUTION**

Remember to always use a chassis guard when using a cross member for lifting.

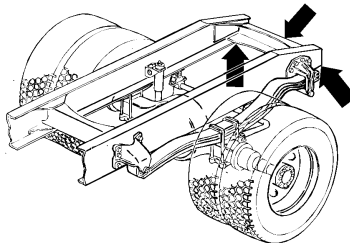

T0006672

Rear suspension lifting points, truck with leaf springs.

10 Addendum

Lifting A Vehicle With Air Suspension

If possible, “Automatic ride height” should be activated during towing. The ignition lock should then be in position I or II.

If “Manual ride height” is activated, set the height to the same drive height as for automatic ride height.

The vehicle must not be driven faster than 10 km/h (6.2 mph) if the air suspension is not activated



WARNING

When you lift a vehicle with air suspension, there is a risk that the air bellows could slide apart. When you lower the vehicle again when you have finished towing, **do not use** your hands **under any circumstances** to guide the air bellows into place again. You risk pinching your hands, which would cause serious injury.

Note: When you lower the vehicle to drive height again, make sure that the bellows are filled with air. When “Automatic ride height” is activated, lower the vehicle carefully to ensure that there is enough time for the bellows to fill with air.

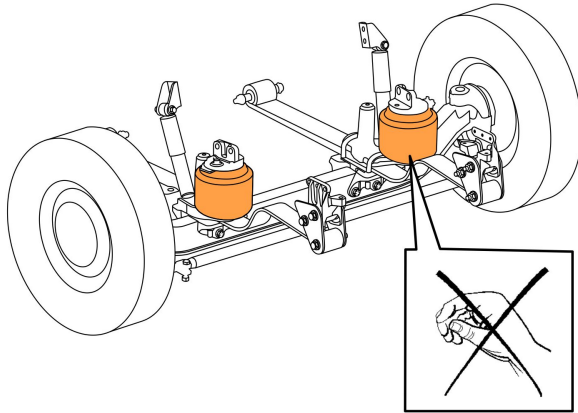

W9094924

Do not use your hands to guide air bellows back into place if they have slid apart.

12 Addendum

Front Suspension

See also “Max. Loading During Lifting and Towing”, page 8 .

Method 1: Wheel Lift

This method provides the greatest ease for towing the vehicle. Lifting at the tires helps reduce the risk of possible damage to the axle, suspension, and engine components during towing operations.

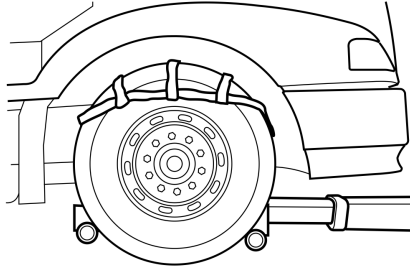

W9094908

Method 2: Axle Fork Lift

This is an alternative procedure for towing the vehicle. It requires standard tow forks and designated lift points depending on which axle is equipped on the vehicle.

For a Steertek NXT equipped vehicle (built after July 2011):

- 1 Use a fork with 3.25” of clearance, a 4.5” opening and 2” shank.
- 2 Install the fork in the boom properly.
- 3 The proper tow fork location is centered between the locknuts on the axle spring seats.

For a Steertek equipped vehicle (built prior to July 2011):

- 1 Install the fork in the boom properly.
- 2 Position the proper tow forks directly under the axle, inside the axle clamp groups.
- 3 Prior to lifting the vehicle, ensure that the bottom axle plate is flat in the tow fork to minimize any gap between the bottom axle plate the tow fork.

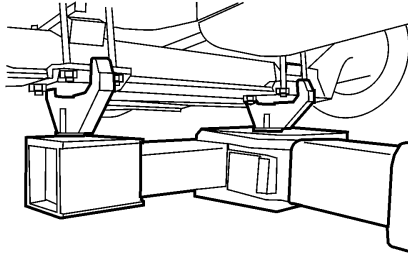

W7001301

Method 3: Spring Eye and Hanger Lift Method

This method is permitted for under lift equipped units, but caution must be taken to avoid damaging the leaf spring.

Note: When lifting a vehicle with the under lift boom, care must be taken to avoid damaging the engine oil pan. It may be necessary to remove the front fairing. If necessary, place a block of wood between the top of the bottom and the bottom of the axle.

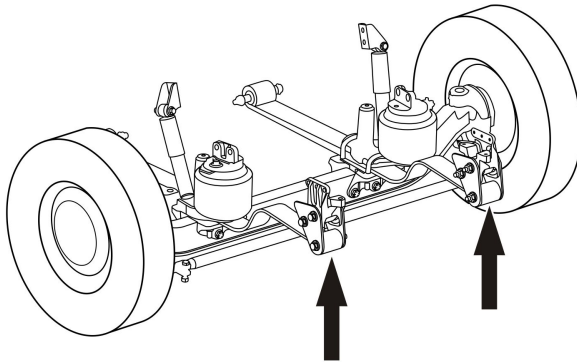

W9094894

14 Addendum

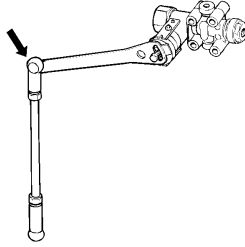

T0006675

Rear Suspension

If possible, avoid lifting the rear of a truck with air springs. The consequence could be that the air bellows slide apart, unless you first secure the rear axle to the chassis. It then takes a lot of time to line up the air bellows again.

Note: If the rear axle is fixed to the chassis with straps etc. when the vehicle is lowered, the straps will burst when automatic ride height control is activated later on.

If you have to lift the rear of the vehicle anyway, lift the towing hitch support cross member in the first instance. If the vehicle does not have a towing hitch support cross member, lift the chassis ends.

If you lift the vehicle by the chassis, the following applies:

- 1 The ignition lock must be in position I or II and the air suspension in “Automatic ride height” mode.
- 2 Lift the chassis until the wheels almost leave the ground. Take a rest until the air has drained out of the air bellows.
- 3 If possible, fix the rear axle to the chassis so that the air bellows can not slide apart.
- 4 Lift to the desired height.

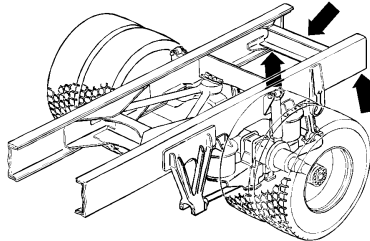

T0006676

Lifting points on rear suspension, truck with air springs.

Towing Configurations (Rear, Side, and Using the Tow Hooks)

Parking Brakes and Towing Hooks

 **WARNING**

The steering does not have any servo effect if the engine is not running.

The parking brake must be released during towing. To mechanically release the parking brake, see under “Parking Brake — Mechanical Release”, page 18.

Use the vehicle's towing hook(s) for towing. If the truck is equipped with **one** towing hook, this may have the gross weight of the truck applied from straight in front. If the truck is equipped with **two** towing hooks, each one of them may have **half** the gross weight of the truck applied from straight in front.

 **WARNING**

the vehicle's towing hook(s) must only be used for towing. Incorrect use can lead to personal injury if the towing hook is loaded with a greater weight than it is dimensioned for.

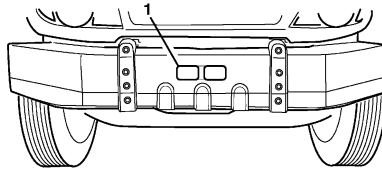

C0029851

1. Tow Hooks

16 Addendum

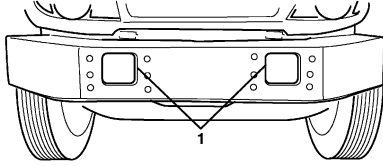

C0029852

1. Tow Hooks

Towing Backwards And Sideways

Towing Backwards

Tow from the rear spring anchorage or trailer hitch hook.

See also “Max. Loading During Lifting and Towing”, page 8 .

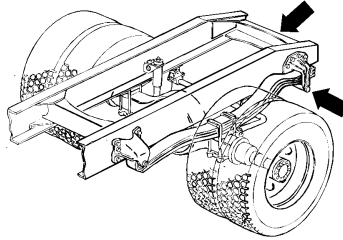

T0006679

Tow from the rear spring anchorage or trailer hitch hook.

Towing Sideways

When towing sideways, select an attachment point close to the axle anchorage, such as a spring or torque stay anchorage. In other cases, the chassis could be subjected to such heavy loading that it could be bent.

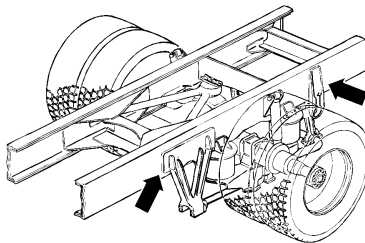

T0006680

Use a spring or torque stay anchorage to tow sideways.

18 Addendum

Releasing The Brake

Parking Brake — Mechanical Release

The parking brake can be released mechanically if compressed air is not available.

Note: Some trucks can have parking brake cylinders on two axles.



WARNING

Always start by applying chocks to the wheels, so that the truck can not roll away. This is very important, since you have to lie underneath the truck to carry on with the job.

- Remove the cap on the rear of the parking brake cylinder. Unscrew the screw until the brake releases. Use the tool from the tool kit.

Note: Do not remove the split pins from designs which have a split pin, unscrew the screw and nut together.

- Remember to screw the screw back to its original place again once you have finished towing, and put the protective cap back.

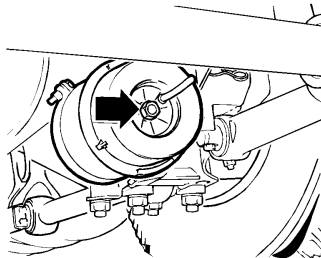

T0006682

Parking brake cylinder.

Disk Brakes

The new brake cylinders have a new release mechanism for the parking brake spring, which means that the release bolt does not come out of the brake cylinder.

When you start to release the parking brake manually, a red plastic plug comes out of the centre of the nut. It is entirely out after three turns. A total of about 45 turns are needed to fully compress the parking brake spring. When the parking brake is fully reinstated, (spring released), the red plastic plug will return into the centre of the nut.

Note: Always fill the parking brake tank with air when available, and release the parking brake, to reduce the amount of turning needed on the release mechanism nut. The nut should only be released in exceptional cases, with no air in the parking brake section.



CAUTION

Under no circumstances is it permissible to use a wrench for manual release or reinstatement of the parking brake!
The maximum torque for the release mechanism nut is 47Nm (34.67 ft-lbs).

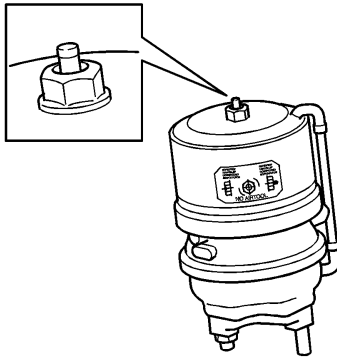

T5011021

Plastic plug for release mechanism

Brakes In Winter

If ice plugs occur in a brake valve in the brake system, the best way to fix this is to heat it with exhaust gas from another vehicle.

Open flames (such as a torch) must not be used since plastic hoses and rubber gaskets can not withstand temperatures higher than 80°C (176°F).

Jump Starting

If the batteries are dead for any reason, you can take current from another vehicle's battery to get the engine going.

In order to avoid an explosion:



WARNING

Batteries which are to be linked together must be of the same voltage (12 to 12, 24 to 24). Take care to observe proper polarity when connecting batteries. Batteries produce explosive gases. Keep sparks, flames, cigarettes, etc., away from batteries at all times. Protect your eyes by wearing safety goggles. Be sure vehicles are NOT touching each other.



WARNING

Remember that batteries, especially help start batteries, contain a hydrogen and oxygen mixture, which is highly explosive. A spark which could occur when you apply the jumper cables incorrectly could be enough to cause the battery to explode and injure you and damage the truck. The battery contains sulphuric acid, which can cause serious chemical burns. If you get any acid in your eyes, skin or clothes — rinse with large quantities of water. If you get any splashes in your eyes, contact a doctor at once.



CAUTION

The battery contains acid which is corrosive and poisonous. It is thus important that the battery is handled in an environmentally compatible manner.



WARNING

Always wear eye protection when working around batteries to prevent the risk of injury due to contact with sulfuric acid or an explosion.



WARNING

Battery posts, terminals and related accessories contain lead compounds, chemicals known to the state of California to cause cancer and reproductive harm. Wash hands after handling.

Note: Your vehicle may be equipped with a jump-start connector which is located on the left rear side of the cab.

- 1 The ignition lock in both trucks should be in position 0.
- 2 Make sure that the battery in the truck which is going to give start help (A) has a total system voltage of 12 V and that the vehicles do not touch each other.
- 3

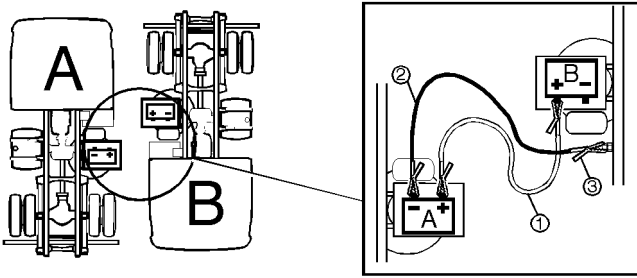

T0006910

- A The truck which gives start help
- B The truck with a dead battery

- 4 Connect the red cable between the positive terminals, (1) on each truck.
- 5 Connect one clamp on the black cable to the negative terminal on truck A, (2).
- 6 Connect the other clamp on the black cable to a ground point a short distance from the battery in truck B, (3).
- 7 Start the engine in truck A. Allow the engine to run at a somewhat higher speed for about a minute, at about 1000 rpm.
- 8 Start the engine in truck B.



WARNING

Check that the clamps are securely attached, so that no sparks occur. Do not lean over the battery during the start attempts.

- 9 Remove the cables in the reverse order from attachment.

Engine Components, Service Schedules

MP7, MP8 and MP10 (US2010 and Newer) Engine Oil Change Intervals

Note: For the MP7, MP8 and MP10 (US2010 and newer) engines, MACK strongly recommends using oils that meet API CJ-4, VDS-4 and EO-O Premium Plus quality standards at all times.

Note: For information about oil change intervals for non-MACK engines, refer to the appropriate engine manufacturer's literature.

MP7, MP8 and MP10 Engines

Note: Use the information in the following table to determine the operating condition and usage applicable to your vehicle.

Engine Operating Condition	Heavy Haul	Regional Haul	Long Haul
Total Fuel Consumption (L/100 km)	>50	<50	<39
Total Fuel Consumption (mpg)	<4.7	>4.7	>6.0
Engine Oil & Filter Change Interval — 42 L (44 quarts) oil capacity	45 000 km (25,000 mi) 625 hours	60 000 km (35,000 mi) 1,000 hours	75 000 km (45,000 mi) 1,300 hours
Engine Oil/ Filter Change Interval — 52 L (55 quarts) oil capacity (MP10 only)	60 000 km 35,000 mi 625 hours	75 000 km 45,000 mi 1,000 hours	80 000 km 50,000 mi 1,300 hours
Note: If idle time is greater than 30%, use the next lower change interval.			

Fuel Tank Ventilation Filter

Some vehicles are equipped with a fuel tank ventilation filter. An exhaust stanchion-mounted filter is designed for use in harsh, abrasive and dirty environments. There are also a fuel tank-mounted filter, a frame rail-mounted filter and a fuel tank bracket-mounted filter for non-severe environments. The purpose of this component is to filter out contaminants that can enter the fuel tank from the vent lines.

This filter should be replaced in conjunction with the vehicle air filter, when indicated by the air restriction gauge or the air filter restrictor indicator light in the instrument cluster. The maximum time allowed before replacement is 24 months.

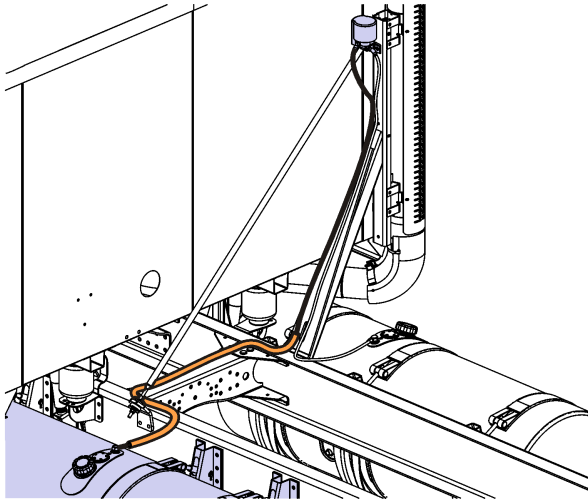

W2069496

Exhaust Stanchion-Mounted Filter

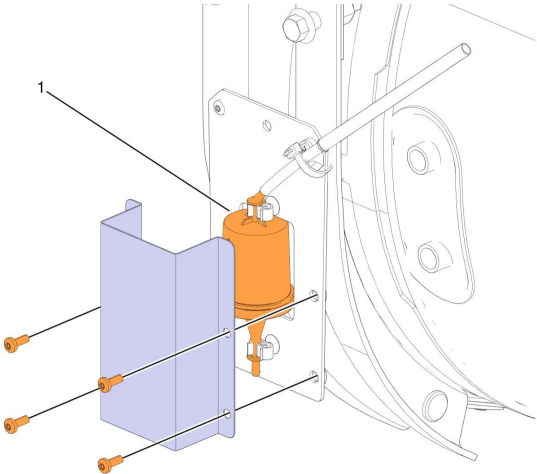

1 – Fuel Tank-Mounted Filter

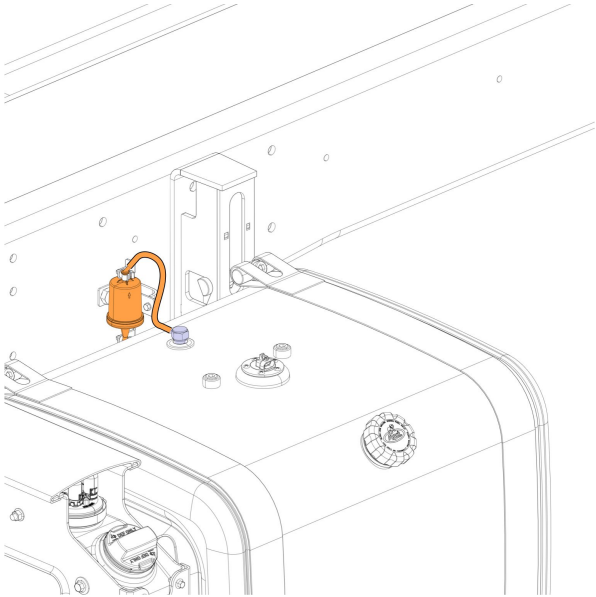

W2085894

Frame Rail-Mounted Filter

Engine Intake Air Cleaner

CAUTION

The condition of the engine intake air cleaner is monitored by the air cleaner restriction gauge mounted on either the air cleaner canister, the air cleaner outlet tube, or inside the cab (dash mounted gauge). Continued operation with the air cleaner gauge indicating a clogged air cleaner may cause damage to the engine. Also, operating the engine with a damaged air cleaner allows dust to pass directly into the engine, causing damage. Promptly replace clogged or damaged air cleaners.

The air cleaner gauge should be inspected regularly to monitor the condition of the air cleaner. Replace the air cleaner when either the air cleaner gauge on the air cleaner locks in the red or when the dash-mounted gauge shows an air inlet restriction of 5 kPa (20 in H₂O). Maximum change interval is 24 months.

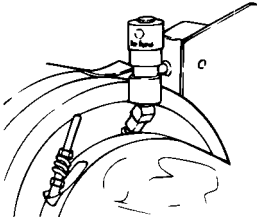

FILTER MOUNTED GAUGE

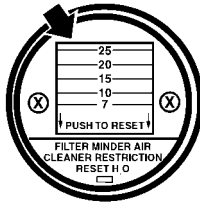

DASH MOUNTED GAUGE

Engine Component Maintenance Intervals

MP7, MP8 and MP10 Engines

Engine Coolant



CAUTION

MACK Trucks, Inc. recommends using a proper mixture of approved antifreeze and deionized or distilled water in the engine cooling system. MACK Trucks, Inc. does NOT recommend using only plain water as a coolant. Water alone is corrosive at engine operating temperatures and does not provide adequate boil-over protection. With plain water as a coolant, the boiling point is lower compared to a proper antifreeze and water mixture, allowing the cooling system to develop corrosion and cavitation problems in the engine and radiator. Failure to follow MACK Trucks, Inc.'s cooling system care/maintenance recommendations can render the warranty invalid.



DANGER

Antifreeze is hazardous to humans and animals if ingested. Always dispose of coolant according to Federal or local regulations. Dispose of used coolant at a recycling or waste collection center.

Note: Fully Formulated Coolant can only be topped off with premixed 50/50 Fully Formulated Coolant when coolant level is low.

Note: Extended Life Coolant can only be topped off with premixed 50/50 Extended Life Coolant when coolant level is low.



CAUTION

Do not top off with water. Topping off with water will dilute the coolant additive package. Once diluted too far the additive will no longer provide sufficient engine protection, which can lead to serious engine damage.

With a manual transmission, the engine coolant system capacity is approximately 50 liters (53 US quarts). With a mDRIVE automatic transmission, the capacity is approximately 59.5 liters (63 US quarts).

28 Addendum

Change the coolant filter and coolant according to the intervals in the following table:

		Heavy Haul – POC S and VS	Regional Haul – POC H	Long Haul – POC M
Coolant Filter	Chemical Additive Filter must be used with Fully Formulated Coolant	At every engine oil change.		
	Long Life Filter without additives to be used with Extended Life Coolant	240 000 km (150,000 mi) or 12 months, whichever comes first		
Coolant	Fully Formulated Coolant	240 000 km (150,000 mi) or 12 months, whichever comes first	500 000 km (300,000 mi) or 24 months, whichever comes first	
	Extended Life Coolant	1 200 000 km (750,000 mi) or 96 months, whichever comes first		

Note: Do NOT use extended-life coolant in engines equipped with a coolant conditioner filter. A coolant filter

that contains no supplemental coolant additives (SCA) is available for use when extended-life coolant is used.

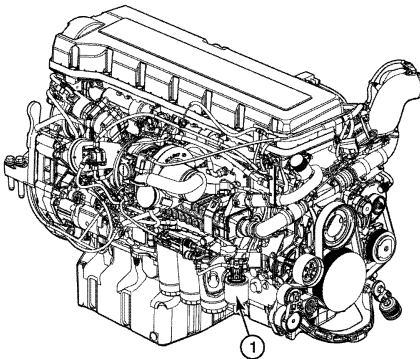

W2055694

Typical Coolant Conditioner Filter Location

Drive Belts (Fan and Accessory)

All engine drive belts have automatic belt tensioners that automatically maintain the correct belt tension without the need for manual adjustment. All drive belts should be checked at each service point and inspected for cracks or frayed material. Replace any drive belt that displays such obvious wear or defects. Otherwise, replace the drive belts according to the intervals in the following table:

US2010 and Newer

For Non-Vocational Applications	500 000 km (300,000 mi) or 36 months, whichever comes first
For Vocational Applications	240 000 km (150,000 mi) or 12 months, whichever comes first

Drive Belt Tensioners

Replace the drive belt tensioner(s) every 500,000 km (300,000 mi.) or 4000 hours, whichever comes first.

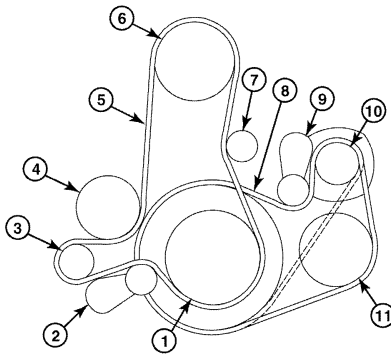

W2055695

Drive Belt Routing – MP7/MP8

30 Addendum

1. Crankshaft Pulley	7. Idler Pulley (if equipped)
2. Automatic Tensioner	8. Accessory Drive Belt
3. Idler Pulley	9. Automatic Tensioner
4. Water Pump	10. Alternator
5. Main Drive Belt	11. A/C Compressor (if equipped)
6. Fan Drive	

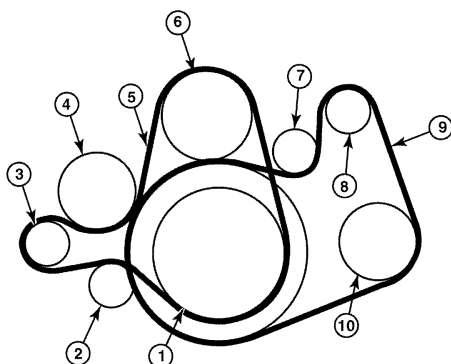

W2055696

Drive Belt Routing – MP10

1. Crankshaft Pulley	6. Fan Drive
2. Idler Pulley	7. Automatic Tensioner
3. Automatic Tensioner	8. Alternator
4. Water Pump	9. Accessory Drive Belt
5. Main Drive Belt	10. A/C Compressor

Engine Valve Adjustments

For US2010 engines and newer, adjust the engine valves according to the intervals in the following table:

MP7, MP8 and MP10 Engines	First Service Adjustment: 240 000 km (150,000 mi) or 12 months, whichever comes first
	Then, adjust every 500 000 km (300,000 mi) or 24 months, whichever comes first

Exhaust Aftertreatment System

Take the vehicle to an authorized MACK Truck dealer for servicing.

Aftertreatment Diesel Particulate Filter (DPF)

Heavy Haul	Regional Haul	Long Haul
Either clean the ash from the DPF or replace the DPF every 400 000 km (250,000 miles) or 4,500 hours, whichever comes first	Either clean the ash from the DPF or replace the DPF every 650 000 km (400,000 miles) or 10,000 hours, whichever comes first	

Aftertreatment Hydrocarbon Doser

For vehicles built through April 2012, **CLEAN** the aftertreatment hydrocarbon doser at 240 000 km (150,000 miles) or 4,500 hours, whichever occurs first.

For vehicles built May 2012 and newer (engine serial numbers: MP7-535298, MP8-961636, MP10-58182), **REPLACE** the aftertreatment hydrocarbon doser at 240 000 km (150,000 miles) or 4,500 hours, whichever occurs first.

Aftertreatment Diesel Exhaust Fluid (DEF) Tank Flushing, DEF Pump Filter and DEF Tank Filler Neck Filter

Drain DEF tank, replace DEF pump main filter and clean DEF tank neck filter at the following intervals.

240 000 km (150,000 mi) or 4,500 hours, whichever occurs first.

Aftertreatment DPF Ignition Electrode and Nozzle

Note: TerraPro model year 2011 to 2013 are equipped with the non-catalyzed thermal regeneration DPF unit (TRU).

Replace the aftertreatment diesel particulate filter (DPF) ignition electrode and nozzle (DPF Spark Assisted System only) every 240 000 km (150,000 mi) or 4,500 hours, whichever comes first.

32 Addendum

Rear Axle Oil Change Intervals

GO-J, GO-J PLUS or TO-A Plus specification gear oil (mineral or synthetic base) are required for MACK rear axle lubrication. The length of time a rear axle can operate before an oil change is required depends on the quality of the oil used and the engine used. For severe service or off-highway applications, more frequent oil changes may be necessary. GO-J is used for standard axle drain intervals. TO-A Plus or GO-J Plus Synthetic **must** be used for extended axle drain intervals.

Powertrain Operating Conditions (POC)													
Transport Cycle	Long Distance			Distribution				Construction ¹					
				Regional			C-city						
GCW (tonnes)	≤ 36	36-48	>48	≤ 30	31-36	>36	≤ 30	≤ 30	≤ 30	30-44	45-55	>56	
GCW (1000 lbs) US and Canada	≤ 80	80-105	>105	≤ 66	67-80	>80	≤ 66	≤ 66	≤ 66	67-95	96-124	>124	
Topography	P-F	H	P-F	H						H	H	H	VH
POC	M-2	M ²	H-2	S-2	VS	M	H	S	S	H	S	V-S	VS+

1 Examples include sugar cane, tipper, dumper, swap carrier, concrete mixer and refuse bodies.

2 If the combined PTO (at zero vehicle speed) and idle time exceeds 25% of total operating time, move to the next higher POC.

The following table shows recommended rear axle oil change intervals:

Powertrain Operating Conditions	Medium (Long Haul)	Heavy (Regional)	Severe (Heavy Haul)	Very Severe	Very Severe +
Maximum Fuel Consumption (litres/100 km)	≤ 39	≤50	≤64	≤ 120	N/A
Maximum Fuel Consumption (mpg)	7.0 – 6.1	6.0 – 4.8	4.7 – 3.8	3.7 – 2.0	N/A
Oil Quality	Driving Distance km (miles) or Time (years/hours) whichever comes first				
GO-J Plus, TO-A Plus	800 000 (500,000) or 3 years	800 000 (500,000) or 3 years	125 000 (80,000) or 1 year or 1200 hours	125 000 (80,000) or 1 year or 1200 hours	6 months
GO-J	400 000 (250,000) or 2 years	400 000 (250,000) or 2 years	65 000 (40,000) or 1 year or 1200 hours	65 000 (40,000) or 1 year or 1200 hours	6 months
For waste collection, mine operation, airport services, etc., engine hours can be used instead of fuel consumption					

Note: TO-A Plus or GO-J Plus Synthetic **must** be used for extended axle drain intervals.

T300 Series Manual Transmission Oil Change Interval

The length of time a manual transmission can operate before a transmission oil change is required depends on the quality of the oil used, the vehicle usage, and engine size. For severe service or off-highway applications, more frequent oil changes may be necessary.

Powertrain Operating Conditions (POC)														
Trans- port Cy- cle	Long Distance				Distribution				Construction ¹					
					Regional			C- ity						
GCW (tons)	≤36		36-48		>48		≤30	3 1-3 6	>3 6	≤3 0	≤30	30-4 4	4 5-5 6	>5 6
GCW (1000 lbs) US and Canada	≤80		80-105		>105		≤66	6 7-8 0	>8 0	≤6 6	≤66	67-9 5	9 6-1 24	>1 24
Topogra- phy	P- F	H	P- F	H							H	H	H	V- H
POC	M- 2,	M ²	H- 2	S- 2	VS	M	H	S	S	H	S	V- S	V- S+	

1 Examples include sugar cane, tipper, dumper, swap carrier, concrete mixer and refuse bodies.

2 If the combined PTO (at zero vehicle speed) and idle time exceeds 25% of total operating time, move to the next higher POC.

The following table shows recommended manual transmission oil change intervals:

Powertrain Operating Conditions	Medium (Long Haul)	Heavy (Regional)	Severe (Heavy Haul)	Very Severe	Very Severe +
Maximum Fuel Consumption (litres/100 km)	≤39	≤50	≤64	≤120	N/A
Maximum Fuel Consumption (mpg)	7.0 – 6.1	6.0 – 4.8	4.7 – 3.8	3.7 – 2.0	N/A
Oil Quality	Driving Distance km (miles) or Time (years/hours) whichever comes first				
GO-J Plus, TO-A Plus	800 000 (500,000) or 3 years	800 000 (500,000) or 3 years	125 000 (80,000) or 1 year or 1200 hours	125 000 (80,000) or 1 year or 1200 hours	6 months
GO-J	400 000 (250,000) or 2 years	400 000 (250,000) or 2 years	65 000 (40,000) or 1 year or 1200 hours	65 000 (40,000) or 1 year or 1200 hours	6 months
For waste collection, mine operation, airport services, etc., engine hours can be used instead of fuel consumption					

Note: Extended change intervals require the use of either GO-J Plus or TO-A Plus Synthetic spec oil.

mDRIVE Transmission Oil Change Intervals

The length of time an mDRIVE transmission can operate before a transmission oil change is required depends on the quality of the oil used and the vehicle application.

The mDRIVE transmission oil change interval depends on the service severity. Always replace the transmission oil filter when the transmission oil is changed and always use MACK-approved synthetic transmission oil when changing the transmission oil.

Powertrain Operating Conditions (POC)													
Transport Cycle	Long Distance			Distribution				Construction ¹					
				Regional			C-city						
GCW (tons)	≤36	3 6-4 8	>48	≤3 0	3 1-3 6	>36	≤3 0	≤30	3 0-4 4	4 5-5 6	>5 6		
GCW (1000 lbs) US and Canada	≤80	8 0-1 05	>10 5	≤6 6	6 7-8 0	>80	≤6 6	≤66	6 7-9 5	9 6-1 24	>1 24		
Topography	P-F	H	P-F	H					H	H	H	VH	
POC	M- ₂	M ²	H- ₂	S- ₂	VS	M	H	S	S	H	S	V-S	V-S+

1 Examples include sugar cane, tipper, dumper, swap carrier, concrete mixer and refuse bodies.

2 If the combined PTO (at zero vehicle speed) and idle time exceeds 25% of total operating time, move to the next higher POC.

Powertrain Operating Conditions	Medium (Long Haul)	Heavy (Regional)	Severe (Heavy Haul)	Very Severe	Very Severe +
Maximum Fuel Consumption (litres/100 km)	≤39	≤50	≤64	≤120	N/A
Maximum Fuel Consumption (mpg)	7.0 – 6.1	6.0 – 4.8	4.7 – 3.8	3.7 – 2.0	N/A
Oil Quality	Driving Distance km (miles) or Time (years/hours) whichever comes first				
97307	400 000 (250,000) or 3 years	400 000 (250,000) or 3 years	N/A	N/A	N/A
97315	400 000 (250,000) or 3 years	400 000 (250,000) or 3 years	200 000 (125,000) or 3 years	200 000 (125,000) or 3 years	2500 hours
97318	800 000 (500,000) or 5 years	800 000 (500,000) or 5 years	N/A	N/A	N/A
97319	800 000 (500,000) or 5 years	800 000 (500,000) or 5 years	400 000 (250,000) or 5 years	400 000 (250,000) or 5 years	2500 hours

For a complete list of approved oils, contact your MACK Truck dealer. Also, refer to SB 175-61, Approved Oils, MACK Components.

Note: No sampling is allowed. System must be undisturbed until oil and filter are replaced.

Power Steering Fluid

The power steering system fluid reservoir is filled with Automatic Transmission Fluid (ATF) Dexron® III. The reservoir contains 1.9 liters (4 US pints) for single gear and 3.8 liters (8 US pints) for dual gear power steering systems.

Change the power steering fluid and filter every 240 000 km (150,000 mi) or 12 months, which ever comes first. Refill the power steering system with the same type of fluid originally used in the system. Refer to the label on the side of the power steering reservoir for the correct fluid.

If the power steering fluid has darkened, the power steering system is running hotter than normal and the fluid is overheating. Troubleshoot the power steering system for possible overheating causes and change the fluid.

For more information on Steering, refer to the Service Information in Function Group 6 and appropriate vendor literature.



Mack Trucks

<http://www.macktrucks.com>