



# OPERATOR'S HANDBOOK

## MAINTENANCE AND LUBRICATION

MP7, MP8, and MP10 Engines

21394653

© Mack Trucks, Inc. 2010  
Printed in U.S.A.

Mack MAINTENANCE AND LUBRICATION OPERATOR'S HANDBOOK 21394653



# OPERATOR'S HANDBOOK

## MAINTENANCE AND LUBRICATION

MP7, MP8, and MP10 Engines

21394653  
April 2010

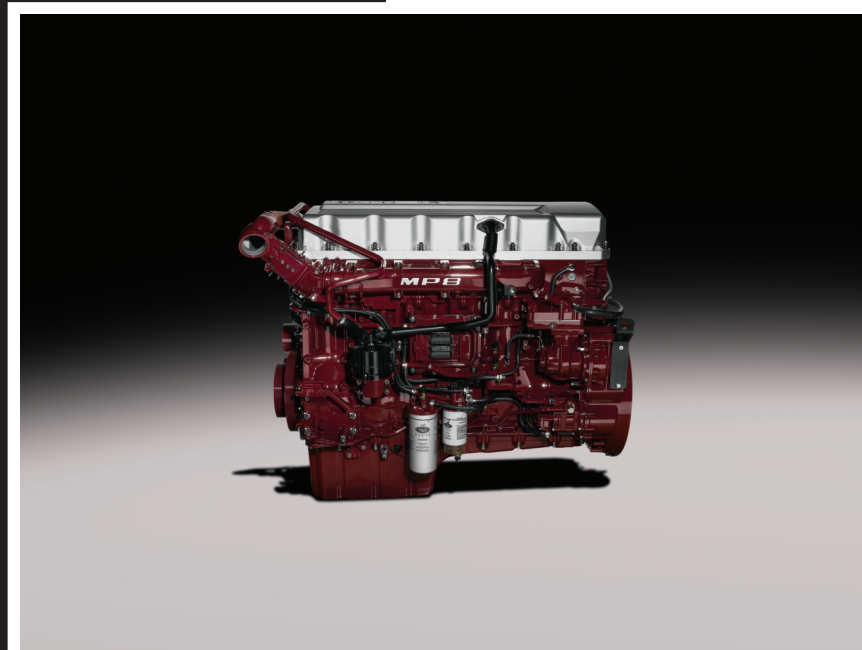



---

# Contents

<b>Operator's Manual Vehicle Maintenance CXU, CHU, GU, TD, MRU and LEU ...</b>	<b>1</b>
Foreword .....	1
Warning Label Information .....	1
General Information .....	3
Information For the Owner .....	3
Federal Emission Requirements .....	5
Label Information .....	12
Safety Information .....	19
Proper Maintenance Procedure .....	19
Injury Prevention .....	22
Engine Damage Prevention .....	30
Electric System Damage Prevention .....	32
Reporting Safety Defects .....	34
General Engine Information .....	35
Engine Overview, MP7 and MP8 Left Side View .....	35
Engine Overview, MP7 and MP8 Right Side View .....	36
Engine Overview, MP10 Left Side View .....	37
Engine Overview, MP10 Right Side View .....	38
Electrical System .....	39
Batteries .....	39
Battery Warmer .....	41
Battery Condition .....	41
Charging .....	42
Load Test .....	44
Electrical Connection Protection .....	44
Precautions When Installing Electrical Equipment .....	47
Engine Storage .....	50
Engine Storage .....	50
Maintenance and Service .....	51
Maintenance Hazards .....	51
Engine Components, Service Schedules .....	51
Cooling System .....	54
Fuel System .....	63
Engine Oil .....	75
Engine Air Filter .....	82
Exhaust After-Treatment System .....	85
Drive Belt Replacement Intervals .....	94
Automatic Belt Tensioner Maintenance .....	102
Turbocharger and Charge Air Cooler .....	106
Preventive Maintenance Air Suspensions .....	109
Steering and Brakes Maintenance .....	110
Tires, Wheels and Hub Maintenance .....	114
Chassis Maintenance .....	128
Cab Maintenance .....	130
Lubrication .....	136
Oil Capacity Tables and Viscosity Charts .....	142
Service Check List .....	146

---

Preventive Maintenance.....	146
Service Charts.....	150
Scheduled Services.....	150
Tire Record.....	154
Fuel and Oil Record.....	155
Engine Data.....	156
Literature.....	157
Service Assistance and Manuals.....	157
CUSTOMER SERVICE.....	158

## Foreword

**DO NOT Remove** this manual from the vehicle. It contains important operational and safety information that is needed by all drivers and owners of this vehicle.

This manual contains information concerning the safe operation of your vehicle. It is extremely important that this information is read and understood before the vehicle is operated. This manual also contains a considerable amount of information concerning the vehicle, such as vehicle identification, Preventive Maintenance recommendations and a log for your service records. Please keep this in the vehicle at all times. Information from other component manufacturers is supplied in separate manuals in the Owners Package.

**Note:** It is important that this manual stay with the vehicle when it is sold. Important safety information must be passed on to the new customer. The service information contained in this manual gives the owner important information about maintaining the vehicle but is not intended as a substitute for the Preventive Maintenance Service Manual and must not be regarded as such.

The National Highway Traffic Safety Administration (NHTSA) and MACK Inc. should be informed immediately if you believe that the vehicle has a defect that could cause a crash, injury or death.

Contact NHTSA by calling the Auto Safety Hotline at 1 (888) 327-4236, by writing to NHTSA, U.S. Department of Transportation, Washington, DC 20590, by TTY at 1 (800) 424-9153, or visit their website at [www.nhtsa.dot.gov](http://www.nhtsa.dot.gov).

**MACK Trucks, Inc.**

Greensboro, NC USA

**Order number: PV776-21394653**

All rights reserved. No part of this publication may be reproduced, stored in retrieval system, or transmitted in any forms by any means, electronic, mechanical, photocopying, recording or otherwise, without the prior written permission of MACK Inc.

## Warning Label Information

**IMPORTANT: Before driving this vehicle, be certain that you have read and that you fully understand each and every step of the driving and handling information in this Operators Manual. Be certain that you fully understand and follow all safety warnings. It is extremely important that this information is read and understood before the vehicle is operated.**

IT IS IMPORTANT THAT THE FOLLOWING INFORMATION CONCERNING LABELS BE READ, UNDERSTOOD AND ALWAYS FOLLOWED.

## 2 Operator's Manual Vehicle Maintenance CXU, CHU, GU, TD, MRU and LEU

---

The following types of labels are used throughout this manual:

**Note:** A note defines an operating procedure, practice, condition, etc., which is essential to proper operation of the vehicle.



### DANGER

A danger label directs the operators attention to unsafe practices which could result in serious personal injury or death. The danger label is in **white** type on a **black** background with a **black** border.



### WARNING

A warning label directs the operators attention to unsafe practices which could result in personal injury or severe damage to the vehicle. The warning label is in **black** type on a **gray** background with a **black** border.



### CAUTION

A caution label directs the operators attention to unsafe practices where personal injury is not likely but property damage could occur. The caution label is in **black** type on a **white** background with a **black** border.

## Warning and Advisory Labels

Advisory, Danger, Warning and Caution labels are placed in various locations of the vehicle to alert drivers and service technicians about situations that may lead to personal injury or equipment damage. In the event that a label is damaged or missing the **label must be replaced**. Contact your authorized MACK Truck dealer for assistance regarding Warning and Advisory labels.

# General Information

## Information For the Owner

If there are questions on the maintenance and performance of your vehicle, please discuss them with your MACK Truck dealer. Your authorized dealer is required to have trained mechanics, special tools and spare parts to fully service your vehicle. If necessary, your dealer will contact MACK Inc. or other manufacturers for any assistance.

In addition to this Maintenance Manual, there may be additional instruction/operators manuals supplied by component manufacturers. These manuals are placed in the Owners Package and placed in the cab. Be sure to read all the manuals thoroughly before operating the vehicle.

Also, various safety labels may be placed on components by the component manufacturer. Be sure to read and follow these labels to prevent damage to the vehicle, personal injury or even death.

Information in this manual refers to MACK components and MACK drivetrain.

Establish a Preventive Maintenance Program with the help of your local MACK Truck dealer. A Preventive Maintenance Program makes it possible to maximize the amount of time your vehicle is up and running, resulting in longer component life. This makes for a safer vehicle by reducing any mechanical failures due to poor maintenance practices.

**Note:** Federal law requires manufacturers to notify owners of its products in the event of a Federal Motor Vehicle Safety Standard or if a safety related defect is discovered. If you are not the original owner of this vehicle, please notify us about the change in ownership at the address below or through an authorized MACK Truck dealer. This is the only way we will be able to contact you if necessary.

MACK Inc.

Northeast Region

7900 National Service Road, Mail: P.O. Box 26259

Greensboro, NC 27402

TEL: (336) 291-9001

United States of America

This Maintenance Manual covers all MACK vehicles manufactured by MACK Inc., including the whole chassis and all MACK manufactured components. For specific maintenance information on vendor components, see the respective manufacturers service and maintenance literature.

This manual, together with manuals for specific components contain important information to be able to operate this vehicle safely. They contain advice and

## 4 Operator's Manual Vehicle Maintenance CXU, CHU, GU, TD, MRU and LEU

---

instructions which will enable you to get the operating economy and performance that you expect from this quality vehicle.

All information, illustrations and specifications contained in this manual are based upon the latest product information available at the time of publication. If any questions arise concerning the current status of Federal or state laws, the appropriate Federal or state agency should be contacted.

**Note:** Illustrations are used for reference only and may differ slightly from the actual vehicle, however, key components addressed in this manual are represented as accurately as possible.

MACK Inc. reserves the right to make changes at any time or to change specifications or design without notice and without incurring obligation.

### General

#### USA

The Federal Clean Air Act, Section 203 (a) (3), states the following concerning the removal of air pollution control devices or modification of a certified engine to a non-certified configuration:

CAA, Section (a) (3) (A) prohibits any person from removing or rendering inoperative any emission control device or element of design installed on or in a motor vehicle or motor vehicle engine in compliance with federal regulations under the Clean Air Act prior to the sale and delivery of the vehicle to the ultimate purchaser. The statute also prohibits any person from knowingly removing or rendering inoperative any emission control device or element of design after sale and delivery of a vehicle or engine to the ultimate purchaser. Any person who violates these provisions either by removing or rendering inoperative emissions control devices prior to the sale or delivery of an engine or vehicle to an ultimate purchaser, or by knowingly removing or rendering inoperative such devices after the sale and delivery of an engine or vehicle to an ultimate purchaser, can be subject to penalties of up to \$3,750 per incident. Any dealer or manufacturer who violates these provisions can be subject to penalties of up to \$37, 500 per incident.

#### Canada

The same conditions that apply in the USA apply to Canada, with one exception. After the vehicle is sold to a retail customer, that is, the end user, the jurisdiction controlling the emission control devices becomes the province in which the vehicle is licensed. No changes should be made that render any or all of the devices inoperative.

Should the owner/operator wish to make any changes to the emission control devices, check with the provincial authority before making any such changes.



## *Mexico*

The same conditions that apply in the USA apply to Mexico. Refer to the Mexican Federal Law for Emission Control which adheres to EPA regulations. No changes should be made that render any or all of the emissions control devices inoperative.

Should the owner/operator wish to make any changes to the emission control devices, check with the state authority before making any such changes.

## **Federal Emission Requirements**

This section covers the requirement of the United States Clean Air Act which states:

The manufacturer shall furnish with each new motor vehicle or motor vehicle engine such written instructions for the maintenance and use of the vehicle or engine by the ultimate purchaser as may be reasonable and necessary to assure the proper functioning of emission control devices and systems.

This section also covers the requirements of the emissions regulations promulgated under the Motor Vehicle Safety Act in Canada.

## 6 Operator's Manual Vehicle Maintenance CXU, CHU, GU, TD, MRU and LEU

---

### Tampering with Gaseous Emission Control Systems Prohibited

The Federal Clean Air Act prohibits the removal or rendering inoperative of any device or element of design installed on or in a motor vehicle or motor vehicle engine in compliance with Federal Emission Regulations by:

- 1 Any person prior to its sale and delivery to the ultimate purchaser, or
- 2 Any manufacturer or distributor after its sale and delivery to the ultimate purchaser, or
- 3 Any person engaged in the business of repairing, servicing, selling, leasing, or trading motor vehicles or motor vehicle engines following its sale and delivery to the ultimate purchaser, or
- 4 Any person who operates a fleet of motor vehicles following its sale and delivery to the ultimate purchaser.

**Note:** For specifics of the prohibited vehicle/engine modifications refer to the MACK Bodybuilder documentation.

### Engines Other than MACK

**For specific information on engines other than MACK, refer to the engine vendors publications.**

### Noise Emissions

MACK Inc. warrants to the first person who purchases this vehicle for purposes other than resale and to each subsequent purchaser, that this vehicle as manufactured by MACK Inc. was designed, built and equipped to conform, at the time it left the control of MACK Inc., with all applicable U.S. EPA Noise Control Regulations.

This warranty covers this vehicle as designed, built and equipped by MACK Inc., and is not limited to any particular part, component or system of the vehicle manufactured by MACK Inc. Defects in design, assembly or in any part, component or system of the vehicle as manufactured by MACK Inc., which, at the time it left the control of MACK Inc. caused noise emissions to exceed Federal standards, are covered by this warranty for the life of the vehicle.

## *Noise Control System, Operator Inspection and Maintenance Requirements*

A Noise Control System Maintenance Log is located in this manual. This log should be used to document all Noise Control System related maintenance, whether the maintenance results from a specific noise control system inspection, or a deficiency identified during another general maintenance event.

If additional log space is needed, further entries may be added on a separate sheet of paper. Store these additions with the main log to preserve a comprehensive record. It is recommended that copies of all noise emissions related maintenance invoices be retained.

The following Noise Control System inspection and maintenance instructions contain suggested maintenance intervals. These intervals may need adjustment in order to best accommodate the specific vehicle usage. The following instructions only concern Noise Emissions related items and do not address or modify any general vehicle maintenance requirements.

The following elements make up the Noise Control System:

- Noise Shielding and Insulation Devices
- Cooling System
- Exhaust System/DPF System
- Air Intake/Air Induction System
- Engine Control, EGR and Fuel Systems
- Selective Catalytic Reduction (SCR)

## *Tampering with Noise Control System*

Federal law prohibits the following acts or the causing thereof:

(1) The removal or rendering inoperative by any person, other than for purposes of maintenance, repair, or replacement, of any device or element of design incorporated into any new vehicle for the purpose of noise control prior to its sale or delivery to the ultimate purchaser or while it is in use;

or

(2) the use of the vehicle after such device or element of design has been removed or rendered inoperative by any person.

Among the acts that constitute tampering are the acts listed below:

- Removal, or rendering inoperative, of any exhaust components, including mufflers, heavy or double-wall exhaust tubing, flexible tubing or exhaust pipe clamping.

## 8 Operator's Manual Vehicle Maintenance CXU, CHU, GU, TD, MRU and LEU

---

- Removal, or rendering inoperative, of the temperature-modulated cooling fan system.
- Removal of the cooling fan shroud.
- Removal, or rendering inoperative, of the air cleaner or air intake in-line silencer.
- Removal of the sound deadening material from the hood or cab tunnel.
- Removal, or rendering inoperative, of the engine speed governor so as to allow engine speed to exceed the manufacturers specifications.
- Removal of splash shields located inside the wheel housings.
- Removal of engine block shields.
- Removal of engine crankcase shields or insulation.
- Removal of insulated rocker arm covers.
- Removal of transmission noise shields.

### *Noise Shielding and Insulation Devices*

#### **Maintenance**

Ensure sound shielding and insulating devices are intact. Inspect components for damage. Primary system components requiring noise related inspection include the hood, engine compartment insulating materials (including hood insulation, bulkhead insulation, doghouse insulation, etc.) splash shields, cab skirts, fender shields, and body panels. Inspect all related fasteners, brackets, and clamps for damage and tightness.

#### **Regulatory Compliance**

Acts that constitute tampering with the Noise Shielding and Insulation Devices:

Removing or rendering inoperative the engine and/or transmission noise deadening panels, shields or insulating materials.

Removing or rendering inoperative the cab-tunnel or hood noise insulating materials.

Removing or rendering inoperative any vehicle body mounted sound insulation components and/or shields (cab or fender shields, skirts, wheel housing splash shields, etc.).

## *Cooling System*



### **WARNING**

DO NOT work near the fan with the engine running or the ignition in the ON position. The engine fan can engage at any time without warning. Anyone near the fan when it turns on could be seriously injured.

## **Maintenance**

Visually inspect cooling system components for damage, and/or misalignment.

Primary system components requiring noise related inspection include fan blades, fan clutch, fan shroud, fan ring, and recirculation shields. Check fan blades, fan ring, fan shroud, belt tensioner and recirculation shields for any damage. Verify that fan blades clear the fan ring. Inspect all related fasteners, brackets, and clamps for damage and tightness. Confirm operation of temperature modulated fan clutch.

## **Regulatory Compliance**

Acts that constitute tampering with the Cooling System:

Removing or rendering inoperative cooling system components (such as the temperature modulated fan clutch, fan shroud, fan ring, recirculation shields, etc.).

## *Exhaust System*



### **WARNING**

Hot engine! Avoid all movable parts or hot engine parts, exhaust gases, and/or fluids. A hot engine, exhaust, and/or fluids can cause burns.

# 10 Operator's Manual Vehicle Maintenance CXU, CHU, GU, TD, MRU and LEU

---

## Maintenance

Make sure the exhaust system is intact. Inspect for damage, misalignment and/or leakage. Primary system components requiring noise related inspection include exhaust manifold, turbocharger, and all exhaust system (rigid and flexible) piping. Closely check the system for exhaust leaks. Special attention should be given to all welds, seams, gaskets, support points, clamps, couplings and connections.

Inspect all exhaust system fasteners, brackets, and clamps for damage and tightness.

## Regulatory Compliance

Acts that constitute tampering with the Exhaust System:

Removing or rendering inoperative exhaust system components (such as the pipes, clamps, etc.).

## *Air Intake/Air Induction System*

### Maintenance

Make sure the air intake system is intact. Inspect components for damage, misalignment and/or leakage. Primary system components requiring noise related inspection include the air cleaner housing, air cleaner element, turbocharger, charge air cooler and intake manifold.

Also inspect all ducts, pipes, hoses, tubing and elbows used to interconnect the system. Special attention should be given to all welds, seams, gaskets, support points, clamps, couplings and connections.

Inspect all intake system fasteners, brackets, and clamps for damage and tightness.

## Regulatory Compliance

Acts that constitute tampering with the Air Intake/Air Induction System:

Removing or rendering inoperative air intake/induction system components (filter, filter housings, ducts, etc.).

*Engine Control, EGR and Fuel Systems*

Acts that constitute tampering with Engine Control, EGR and Fuel Systems:

Removing rendering inoperative, or modifying the engine control system such as the ECU, EGR system components, or fuel system components, in order to allow the engine to operate outside of the manufacturers specifications is not allowed and violates both warranty and legislation.

# 12 Operator's Manual Vehicle Maintenance CXU, CHU, GU, TD, MRU and LEU

---

## Label Information

### Vehicle Identification Number Label

All motor vehicles are required to be identified by a 17-digit Vehicle Identification Number (VIN). U.S. and Canadian regulations dictate the format of the number. The VIN gives specific information about the vehicle as manufactured by MACK, such as type of vehicle, model, type of brake system, gross vehicle weight range and model year.

The VIN can be found at several different locations on a MACK vehicle. Locations include a stamping on the vertical face of the right-hand frame rail (somewhere between the front spring hanger brackets), a VIN label inside the cab (on the door edge, the door opening area or the seat riser) and on the vehicle safety certification labels and other labels on the door edge or door opening area. When the vehicle is received, check the VIN at each location on the vehicle and verify that they are identical. The vehicle identification number must not be changed, covered or obliterated.

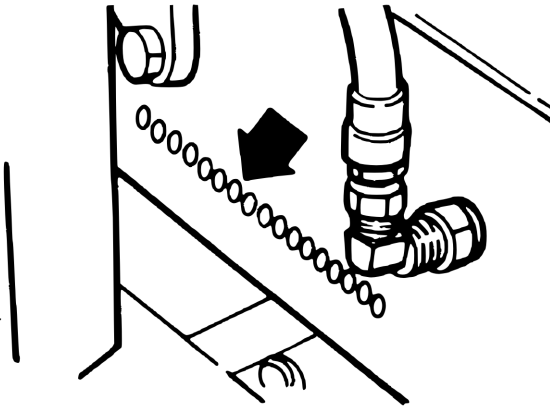

001289a

W0031972

VIN Frame Stamping



# Operator's Manual Vehicle Maintenance CXU, CHU, GU, TD, MRU and LEU 13

---



**MACK TRUCKS, INC.**

**MODEL NO.: X000XX  
SEQ. NO.: XX00**

**VIN: OXOX000X0XXX00000 4MR21084**

006690a

W0031973

VIN Label on Drivers Seat Riser

# 14 Operator's Manual Vehicle Maintenance CXU, CHU, GU, TD, MRU and LEU

---

## Regulatory Labels

In addition to, or in place of the previously mentioned labels, MACK Trucks, Inc. may affix one or more of the following labels to the cab.

### Heater/Defroster Omission Label

A windshield defroster, as required by FMVSS 103, *Windshield Defrosting and Defogging*, is not required for vehicles destined for sale in the State of Hawaii, Puerto Rico, the Northern Mariana Islands, Guam, the Virgin Islands and American Samoa. Vehicles destined for sale in these areas must, however, conform to all other applicable FMVSS regulations. If a vehicle destined for sale in one of these areas does not have a factory-installed defroster, a label is affixed to the cab near the vehicle certification label (see illustration below).

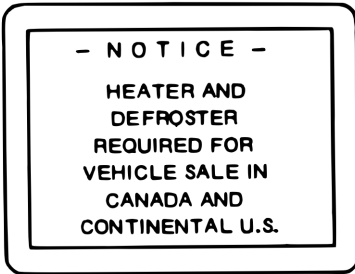

000238a

W0031974

Omission of Heater/Defroster Label

## **Export Label**

In order to comply with U.S. regulations, all MACK vehicles intended for export from the United States (including export to Canada) will have an Export Label, similar to the label shown below, affixed to the inside of the windshield.



**AFFIXED TO WINDSHIELD.**

006702a

W0031975

Typical Export Label (Including Export  
to Canada)

# 16 Operator's Manual Vehicle Maintenance CXU, CHU, GU, TD, MRU and LEU

---

## Export/Special Application Label

Export (excluding export to Canada) or special application vehicles supplied from the assembly plant are not necessarily designed to conform to applicable Federal and Canadian motor vehicle safety standards. On these vehicles, an Export/Special Application Label, similar to the label shown in the illustration below, is affixed to the cab.

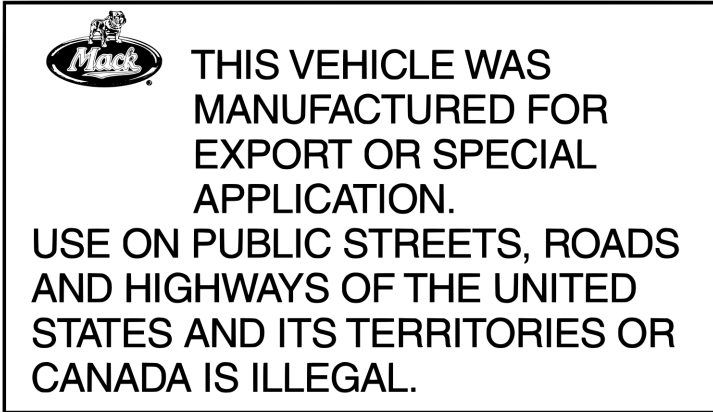

000239b

W0031976

Export/Special Application Label

# Operator's Manual Vehicle Maintenance CXU, CHU, GU, TD, MRU and LEU 17

---

Export vehicles (other than those intended for sale in Canada) also have an Export Label, similar to the label shown below, affixed to the door area.

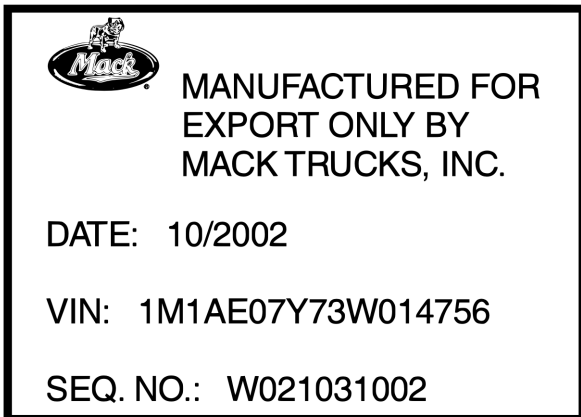

**AFFIXED TO DOOR AREA.**

006703a

W0031977

Typical Export Label (Other Than Export  
to Canada)

# 18 Operator's Manual Vehicle Maintenance CXU, CHU, GU, TD, MRU and LEU

---

## Off-Highway Identification Label

In addition to the Export/Special Application Label, vehicles designed strictly for off-highway operations will have an Off-Highway Identification Label, similar to the label shown in the illustration below, affixed to the cab.

	MANUFACTURED BY MACK TRUCKS, INC. SOLELY FOR OFF HIGHWAY USE DATE: 10/2002 GVWR: 23587 KG ( 52000 LB) FRONT AXLE GAWR: 5443 KG ( 12000 LB) FIRST INT. AXLE GAWR: 9072 KG ( 20000 LB) 2ND INT. AXLE GAWR: KG ( LB) 3RD INT. AXLE GAWR: KG ( LB) REAR AXLE GAWR: 9072 KG ( 20000 LB) VIN: 1M1AE07Y73W014576	4MR2952
--	--	---------

000240b

W0031978

Off-Highway Identification Label

## Safety Information

### Proper Maintenance Procedure



#### **DANGER**

Before working on a vehicle, set the parking brakes, place the transmission in neutral, and chock the wheels. Failure to do so can result in unexpected vehicle movement and can cause serious personal injury or death.



#### **DANGER**

Exhaust gases contain carbon monoxide. Always run the engine outdoors or use a properly vented exhaust hose. Prolonged or excessive exposure may cause serious illness or death.



#### **DANGER**

Never operate the engine in an area where hydrocarbon vapors (gasoline, for example) are present or are suspected to be present. Hydrocarbon vapors can enter the air intake and over speed the engine, causing severe engine damage and/or an explosion and fire. Serious personal injury or death could occur.



#### **DANGER**

Never try to operate or work on this vehicle while under the influence of alcohol. Your reflexes can be affected by even a small amount of alcohol. Drinking and operating this vehicle can lead to an accident, causing serious personal injury or death.

# 20 Operator's Manual Vehicle Maintenance CXU, CHU, GU, TD, MRU and LEU

---



## WARNING

DO NOT attempt to repair or service this vehicle without having sufficient training, correct service literature and the proper tools. Failure to follow this could lead to personal injury or making your vehicle unsafe.



## WARNING

Diesel engine exhaust and some of its constituents are known to the state of California to cause cancer, birth defects and other reproductive harm.

## During Maintenance

Remove key from ignition while working on vehicle or engine.

**DO NOT allow unauthorized personnel on, around or in the vehicle when maintenance or repair is being performed.**

- When operating the engine in an enclosed area, vent the exhaust to the outside.
- Before servicing your vehicle, apply the parking brakes and adequately chock the wheels in order to prevent unintended vehicle movement. If the service procedure requires the parking brakes to be released recheck to ensure that the wheels are adequately chocked to prevent any forward and/or rearward movement.
- DO NOT use combustible substances in or around the engine either during repair or maintenance or when running the engine.
- DO NOT wear loose clothing or jewelry that can catch or get snagged by parts or moving components on the engine. Also wear all protective equipment required by the job conditions, such as protective glasses, hearing protection, etc.
- Make certain that all protective covers and guards are in place and properly secured.
- Never put maintenance fluids into glass containers since glass containers can break.
- Report all problems in a timely manner before they threaten the safety of operating the vehicle.
- DO NOT work on the engine while it is running.
- Make sure protective locks and covers are in their proper place.
- DO NOT use high amperage electronic starting devices for jump-starting the engine. Rely on conventional battery charging for charging the batteries or jump-start with the help of a start battery.



- DO NOT attempt repairs you do not understand. If you do not have the proper tools/knowledge to perform the repairs correctly, MACK recommends contacting your nearest MACK Truck dealer for all necessary repairs.
- When starting an engine after repairs have been made to the fuel or injection system, prepare equipment for shutting off the engine intake air and/or fuel supply (to stop the engine), in case there is an over speed on start-up.
- Start the engine only from the driver seat. Never operate the starter motor across the starter terminals or the batteries as this could bypass the engine neutral-start system as well as causing damage to the electrical or electronic systems.

## Compressed Air and Water



### DANGER

Compressed air can cause serious personal injury. When using compressed air for cleaning, wear a protective face shield, protective clothing and protective shoes. Pressurized water could cause particles and/or hot water to be sprayed in your direction and cause personal injury. The maximum air pressure must be below 30 psi (200 kPa) for cleaning purposes.

## Asbestos Information

**Note:** The MACK engine and replacement parts for it shipped from the factory are asbestos free. MACK recommends the use of only genuine MACK spare parts. Never use any parts that contain or are thought to contain asbestos. Exposure to asbestos fibers can create serious health risks, including death.

## Fluid Penetration



### DANGER

Always use a piece of paper or cardboard when checking for a leak. Escaping fluid under high pressure, even a pin-hole sized leak, can penetrate body tissue, causing serious injury or death. If fluid is injected into your skin, immediate treatment must be administered by a doctor familiar with this type of injury.

# 22 Operator's Manual Vehicle Maintenance CXU, CHU, GU, TD, MRU and LEU

---

## Injury Prevention

### Burn Prevention

#### *Engine Parts*



#### **WARNING**

Hot engine. Keep yourself clear of all hot engine parts and/or fluids. A hot engine and/or fluid can cause serious burns.



#### **WARNING**

DO NOT raise the engine hood if you see or hear steam or coolant escaping from the engine compartment. Wait until steam or coolant cannot be seen or heard any longer before raising the hood.

DO NOT remove the coolant fill cap if the coolant in the surge tank is boiling. Also, do not remove the cap while the engine and radiator are still hot. Scalding fluid and steam may be blown out under pressure if the cap is taken off too soon, which can cause personal injury and damage to engine components.



W0001525

DO NOT touch any part of the engine while it is hot. Allow the engine to cool before any repair or maintenance is performed on the engine.

Relieve all pressure in air, oil, fuel or cooling systems before any lines, fittings or related items are disconnected or removed.

## Coolant



### WARNING

Coolant may be combustible. Coolant leaked or spilled onto hot surfaces or electrical components can cause a fire. Clean up coolant spills immediately.



W0001527

To prevent personal injury, do not climb up on the engine to remove the filler cap. Use a suitable, properly positioned ladder to reach the cap. At normal operating temperature, the engine coolant is very hot and under pressure. If pressure is relieved rapidly in a hot cooling system, the hot coolant can turn into steam. Any contact with hot coolant or steam can cause severe burns. The radiator and all heating system and radiator lines and hoses contain hot coolant.

Verify coolant level only by the markings on the expansion tank. Open the filler cap only after the engine is stopped and cooled down. Remove the filler cap slowly to relieve pressure.

## Oils



### WARNING

Hot engine. Keep yourself clear of all hot engine parts and/or fluids. A hot engine and/or fluid can cause serious burns.

Hot oil can cause severe burns. DO NOT allow hot oil to contact the skin. When changing oil, wear protective gloves.

## 24 Operator's Manual Vehicle Maintenance CXU, CHU, GU, TD, MRU and LEU

---

### Batteries



#### WARNING

Always wear eye protection when working around batteries to prevent the risk of injury due to contact with sulfuric acid or an explosion.



#### WARNING

Battery posts, terminals and related accessories contain lead and lead compounds, chemicals known to the State of California to cause cancer and reproductive harm. Wash hands after handling.

Battery electrolyte contains acid and can cause injury. Avoid contact with the skin and eyes. Wash hands after touching batteries and connectors. Use of gloves is recommended. Always wear protective glasses when working with batteries.

### Speed Restrictive Tires



#### DANGER

Operating a vehicle equipped with speed restrictive tires in excess of their stated rating may result in tread separation and/or blowout resulting in the loss of steering control and possible collision. Serious personal injury or death could occur. Always maintain proper air pressure and never exceed the tire ratings.

When a vehicle is equipped with speed restrictive tires, DO NOT operate the vehicle in excess of the indicated speeds. If your vehicle is equipped with such tires, the speed restrictions will be stated on the sidewall of the tires. The operator of this vehicle is urged to check the tires of the vehicle to determine if there are any limitations.

## Fire or Explosion Prevention



### DANGER

The diesel engine will operate on any fuel which enters the cylinder, whether it is from the injectors or from the air intake system. Therefore, if any solvent is used to flush out the air cleaner element, the engine may over speed during start-up. Engine damage and severe injury and/or death from burns or explosion can occur.



### DANGER

Excessive heat may cause the pressurized components of the air conditioned system to explode. Some mixtures of R134a refrigerant can become combustible at elevated pressures. Never weld, solder, steam clean or use a gas torch near any part of the air conditioning system. Severe injury or death may occur from an explosion.



W0001526



### DANGER

DO NOT service any part of the fuel system while smoking or in the presence of flames, sparks or hot surfaces. Failure to follow these precautions can result in fire, which can cause serious injury or death.



### WARNING

DO NOT store fuel containers in the vehicle. They may leak, explode and cause or feed a fire. Empty or full, they present a hazard that may lead to burns in the event of a fire.

## 26 Operator's Manual Vehicle Maintenance CXU, CHU, GU, TD, MRU and LEU

---



W0001527

The engine should not be operated in an area where combustible gases are suspected to be in the air. These could be drawn into the engine through the engine air intake system and could cause the engine to over speed with possible serious damage to the engine and bodily injury or property damage.

Make provisions for shutting off the engine intake air or fuel supply to stop the engine if there is an over speed on start-up after performing repair or maintenance on it.

Contact your nearest MACK Truck dealer for any necessary air conditioning testing or repairs.

All fuels, most lubricants and some coolant mixtures are flammable. Diesel fuel is flammable. Gasoline is flammable. The mixture of diesel and gasoline fumes is extremely explosive. DO NOT smoke while refueling or when in a refueling area.

Keep all fuels and lubricants stored in properly marked containers and away from all unauthorized personnel. Store oily rags or other flammable material in a protective container, in a safe place.

Remove all flammable material such as fuel, oil and other substances before they accumulate on the engine.

DO NOT expose the engine to flames, driving over burning ground.

DO NOT weld or flame cut on or around pipes or tubes that contain flammable fluids.

Exhaust heat shields may be installed to protect oil or fuel carrying lines and pipes from hot exhaust parts. To protect from pipe or seal failure, install heat shields correctly.

Provide adequate and proper waste oil disposal. Always dispose of waste liquids according to Federal and local regulations. Oil and fuel filters should be properly installed and housing covers tightened to the proper torque when being changed.

## Starting Aids



### DANGER

DO NOT use ether or other combustibles starting aids on any engine equipped with a preheater. If the engine is equipped with a preheater, introduction of ether or similar starting aids could cause a fire or explosion resulting in severe property damage, serious personal injury or death.

**DO NOT use ether or other combustibles starting aids on engines that have a heater element or other heating devices installed in the intake manifold for heating the intake air during cold-starts.**

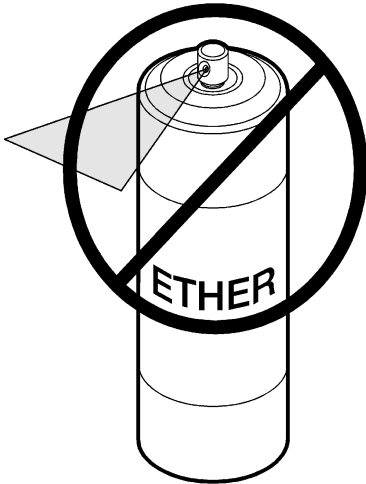

W0001484

## Fire Extinguisher

Anytime work is being done to the fuel system or any other area where flammable substances are being used, have a fire extinguisher available and know how to use it. Inspect and have it serviced as recommended on its instruction label.

# 28 Operator's Manual Vehicle Maintenance CXU, CHU, GU, TD, MRU and LEU

## *Respiratory Hazard Prevention*



### **DANGER**

Exhaust gases contain carbon monoxide. Always run the engine outdoors or use a properly vented exhaust hose. Prolonged or excessive exposure may cause serious illness or death.



### **WARNING**

Diesel engine exhaust and some of its constituents are known to the state of California to cause cancer, birth defects and other reproductive harm.



W0001523

Always work in a well ventilated space if the engine needs to be running and use a hose to route the exhaust to the outside.

## *Poisonous Substances*



### **DANGER**

Coolant is toxic; risk of poisoning. DO NOT drink coolant. Use proper hand protection when handling. Keep coolant out of reach of children and animals. Failure to follow these precautions can cause serious illness or death.

Cooling system supplemental additive contains alkali. To prevent personal injury, avoid contact with the skin and eyes.

DO NOT drink coolant of any concentration.



## Crushing or Cutting Prevention



### DANGER

Before working on a vehicle, set the parking brakes, place the transmission in neutral and chock the wheels. Failure to do so can result in unexpected vehicle movement and can cause serious personal injury or death.



### WARNING

DO NOT work near the fan with the engine running or the ignition in the ON position. The engine fan can engage at any time without warning. Anyone near the fan when it turns on could be seriously injured.



W0001524

Never attempt adjustments or repairs while the engine is running, see your authorized MACK Truck dealer.

Inspect the fan blade assembly before service for cracks or loose mounting before starting the engine. *Never* stand alongside a rotating fan assembly, particularly at high fan speeds.

Wear protective glasses when striking objects to avoid injury to your eyes. Chips or other debris can fly off objects that are struck. Make sure no one can be injured by flying debris before striking any object.

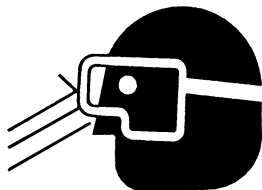

W0001528

# 30 Operator's Manual Vehicle Maintenance CXU, CHU, GU, TD, MRU and LEU

---

## *Climbing Up and Down*



### **DANGER**

Always have three limbs (one foot and two hands or two feet and one hand) in contact with the vehicle at all times when entering or exiting the cab or the area behind the cab. Failure to follow this warning can result in serious personal injury or death.

DO NOT climb up on or jump off from the engine or stand on components that cannot support your weight. Use an adequate ladder or scaffolding, suitably situated.

DO NOT use top of engine or cowlage ledge as foothold when reaching on top of cab. Clean steps, handholds and areas of the vehicle on which you will be working or are around. Refer to the Operators Manual for proper entry and exit procedures.

**Always use a three-point stance (two hands and one foot or one hand and two feet) whenever climbing up or down.**

## **Engine Damage Prevention**

### **Before Starting the Engine**



### **DANGER**

Before working on a vehicle, set the parking brakes, place the transmission in neutral and chock the wheels. Failure to do so can result in unexpected vehicle movement and can cause serious personal injury or death.

Inspect engine for potential hazards. Make sure all protective guards and covers are properly installed if an engine needs to be started to make adjustments or checks. To help prevent an accident by moving parts, work carefully around them.

DO NOT disable or bypass automatic alarm/shutoff circuits. They are provided to prevent personal injury and engine damage.

Only properly trained and authorized MACK Service Technicians may attempt repairs on this vehicle.

## Engine Starting

DO NOT start the engine or move any of the controls or disengage the parking brake if the warning tag DO NOT OPERATE is attached to the ignition key or located on the dash. Check with the person who attached the tag before starting.

Make sure no one is working on or close to the engine or components driven by the engine before starting it. Always make an inspection of the engine before and after starting.

Diesel engine exhaust contains products of combustion which may be harmful to your health. Always start and operate the engine in a well-ventilated area, and if in an enclosed area, vent the exhaust to the outside.

Start the engine only from the driver seat in the cab. Never start the engine by shorting across the starter motor terminals or batteries to start the engine as this could bypass the engine neutral-start system as well as damage the electrical and electronic system. Always start the engine according to the required engine starting procedure described in this operators manual to prevent major engine component damage and personal injury.

# 32 Operator's Manual Vehicle Maintenance CXU, CHU, GU, TD, MRU and LEU

## Electric System Damage Prevention

### Electric and Electronic Systems



#### WARNING

Always wear eye protection when working around batteries to prevent the risk of injury due to contact with sulfuric acid or an explosion.



W0001526

Never disconnect any charging unit circuit or battery circuit cable from the battery when the charging unit is operating. A spark can cause the flammable vapor mixture of hydrogen and oxygen to explode.

To prevent potential sparks from igniting combustible gases produced by some batteries, attach the negative (-) terminal last when hooking up and remove the negative terminal first after the engine has started. Check regularly around the engine and engine compartment for loose or frayed wires. Have all loose or frayed electrical wires tightened, repaired or replaced before operating the vehicle.

### *Grounding Practices*

Proper grounding for vehicle and engine electrical and electronic systems is necessary for proper vehicle and engine performance and reliability. Improper grounding will result in uncontrolled and unreliable electrical paths.

Uncontrolled engine electrical circuit paths can result in damage to main bearings, crankshaft journals surfaces and aluminum components. Uncontrolled electrical circuit paths can also cause electrical noise which may degrade vehicle and radio performance.

Operating engines without the engine-to-frame ground strap installed can cause damage to the engine. To prevent electrical discharge damage, check to make sure the engines electrical system has an engine-to-frame ground strap. All ground connections should be tight and free of corrosion.

## *Electronic Engine Control System*



### **DANGER**

The engine uses high voltage to the electronic unit injectors. DO NOT come in contact with the unit injector terminals while the engine is running. An electric shock can cause an involuntary muscle spasm and cause loss of balance and falls leading to severe personal injury or death.



W0001522

Tampering with the electronic system installation can be dangerous and could result in personal injury or death and/or engine damage. It is very important to take the proper precautions with the electrical and electronic system when charging the batteries, jump-starting or performing electric welding on the vehicle. See the vehicle Operators Manual for correct procedures.

This engine is equipped with monitoring features that may cause reduced power or shutdown under certain conditions. The power output, monitoring and idling features can only be programmed and/or changed with electronic service tools and passwords.

Certain features, such as low oil pressure, high coolant temperature or low coolant level could cause the engine power and/or vehicle speed to be limited and the engine may also shut down. The shutdown will take approximately 30 seconds from the time the warning feature is activated. See the vehicle Operators Manual for more information.

# 34 Operator's Manual Vehicle Maintenance CXU, CHU, GU, TD, MRU and LEU

---

## Reporting Safety Defects

### USA

The National Highway Traffic Safety Administration (NHTSA) and MACK Inc. should be informed immediately if you believe that the vehicle has a defect that could cause a vehicle accident, injury or death.

Contact NHTSA by calling the Auto Safety Hotline at 1 (888) 327-4236, by writing to NHTSA, U.S. Department of Transportation, Washington, DC 20590, by TTY at 1 (800) 424-9153, or visit their website at [www.nhtsa.dot.gov](http://www.nhtsa.dot.gov).

### Canada

Refer customer complaints to MACK Trucks Canada, Inc. or to Transport Canada, Defect Investigations and Recalls.

Canadian customers who wish to report a safety-related defect to Transport Canada, Defect Investigations and Recalls, may telephone the toll free hotline 1 (800) 333-0510 (within Canada only) or call 1 (613) 993-9851 (from Ottawa region or outside Canada). Contact Transport Canada by mail at: Transport Canada, ASFAD, Place de Ville Tower C, 330 Sparks Street, Ottawa ON K1A 0N5.

For additional road safety information, please visit the Road Safety website at: <http://www.tc.gc.ca/roadsafety/menu.htm>

### Mexico

MACK Trucks de Mexico, S.A. de C.V. should be informed immediately if you believe the vehicle has a defect that could cause a vehicle accident, injury or death. Contact MACK Trucks de Mexico by calling: 01 (800) 90 94 900 (within Mexico only) or 011-52-55-50-81-68-50, or by writing to: MACK Trucks de Mexico, S.A. de C.V., Prol. Paseo de la Reforma 600, 1er. Piso 121, Col. Santa Fe Pea Blanca, C.P. 01210, Mexico, D.F.

**Note:** For Roadside assistance information see “CUSTOMER SERVICE”, page 158.

## General Engine Information

### Engine Overview, MP7 and MP8 Left Side View

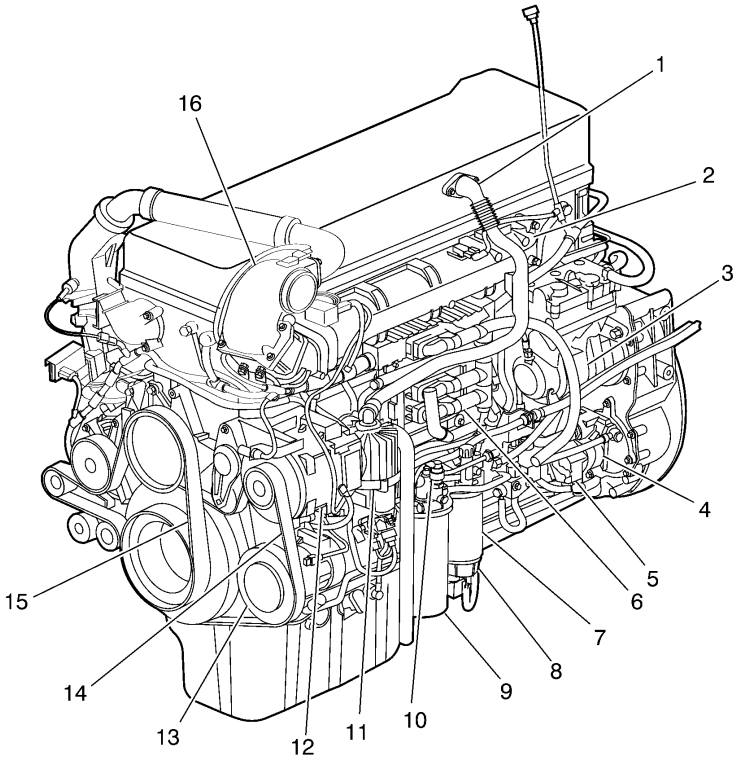

W2006034

MP8 Engine Shown, MP7 Engine Similar

1. Breather Tube	9. Fuel Filter
2. Intake Manifold	10. Hand-Priming Pump
3. Air Compressor	11. Crankcase Ventilator
4. Power Steering Pump	12. Alternator
5. Fuel Pump	13. AC Compressor
6. Engine Control Module (ECM)	14. Alternator/AC Compressor Belt
7. Fuel Filter	15. Fan/Coolant Pump Belt
8. Fuel/Water Separator	16. EGR Mixing Chamber

# 36 Operator's Manual Vehicle Maintenance CXU, CHU, GU, TD, MRU and LEU

## Engine Overview, MP7 and MP8 Right Side View

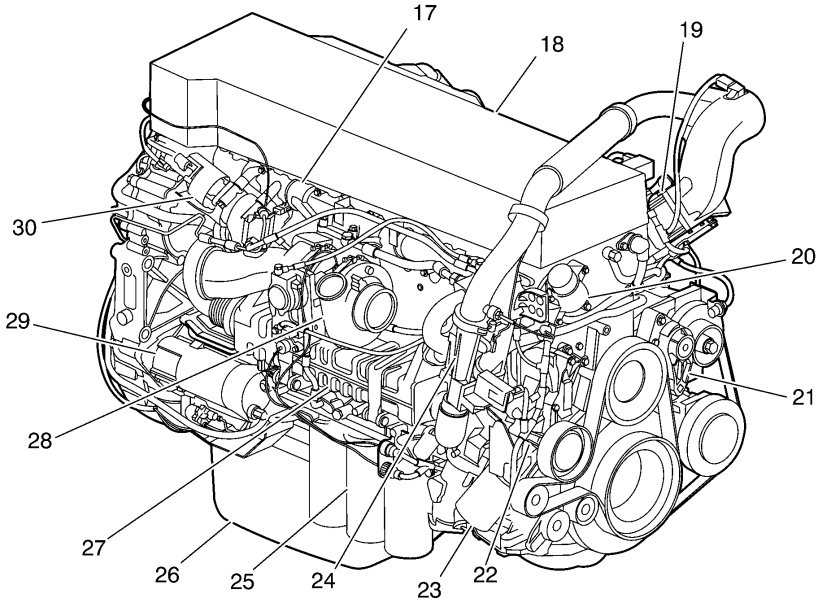

W2006035

MP8 Engine Shown, MP7 Engine Similar

17. Exhaust Manifold	24. Venturi Pipe
18. Valve Cover	25. Oil Filters
19. Intake Air Heater (IAH) optional	26. Oil Pan
20. Thermostat	27. EGR Cooler
21. Belt Tensioner	28. Turbocharger
22. Coolant Pump	29. Starter Motor
23. Coolant Filter	30. EGR Valve



## Engine Overview, MP10 Left Side View

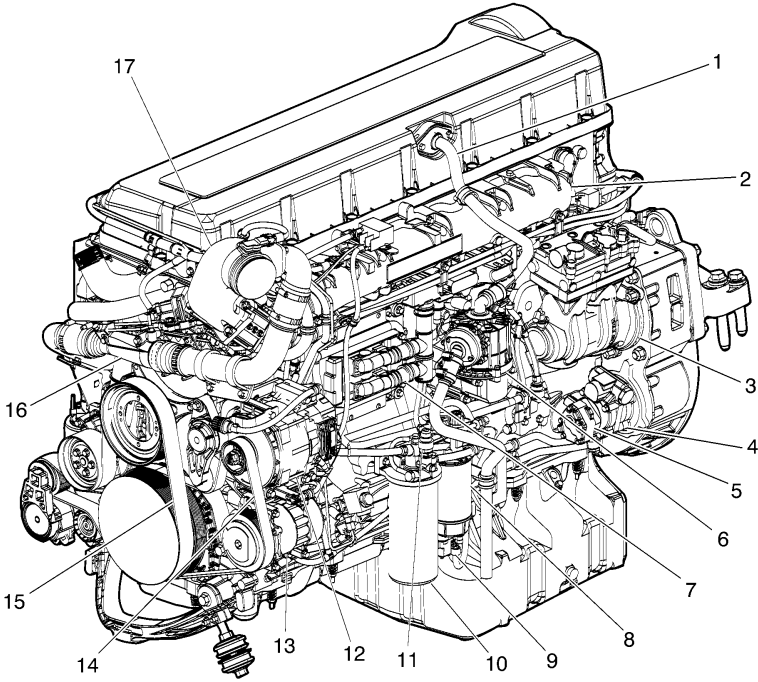

W2006037

- |                                |                                   |
|--------------------------------|-----------------------------------|
| 1. Breather Tube               | 9. Fuel/Water Separator           |
| 2. Intake Manifold             | 10. Fuel Filter                   |
| 3. Air Compressor              | 11. Hand-Priming Pump             |
| 4. Power Steering Pump         | 12. Alternator                    |
| 5. Fuel Pump                   | 13. AC Compressor                 |
| 6. Crankcase Ventilator        | 14. Alternator/AC Compressor Belt |
| 7. Engine Control Module (ECM) | 15. Fan/Coolant Pump Belt         |
| 8. Fuel Filter                 | 16. Venturi Pipe                  |
|                                | 17. EGR Mixing Chamber            |

# 38 Operator's Manual Vehicle Maintenance CXU, CHU, GU, TD, MRU and LEU

## Engine Overview, MP10 Right Side View

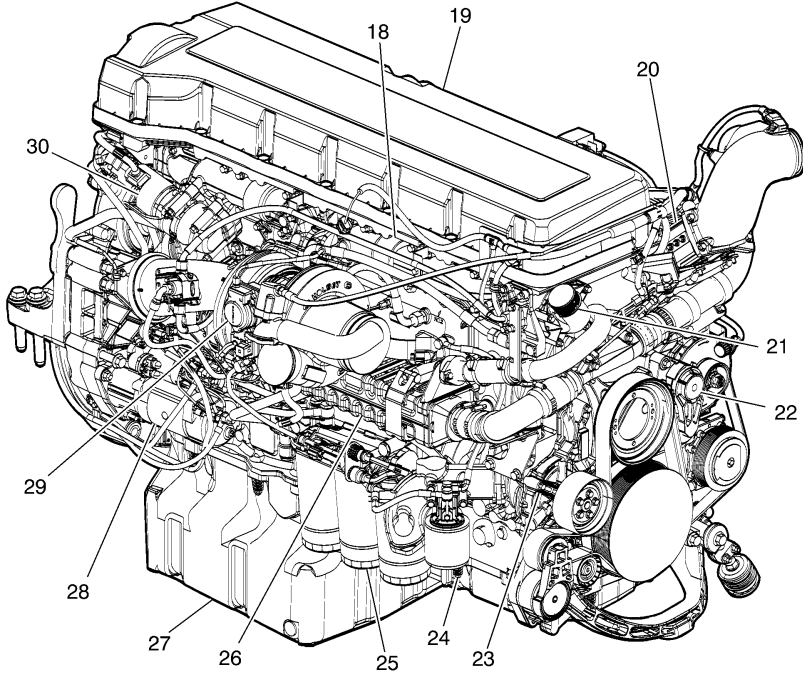

W2006036

18. Exhaust Manifold	24. Coolant Filter
19. Valve Cover	25. Oil Filters
20. Intake Air Heater (IAH)	26. EGR Cooler
21. Thermostat	27. Oil Pan
22. Belt Tensioner	28. Starter Motor
23. Coolant Pump	29. Turbocharger
	30. EGR Valve

## Electrical System

### Batteries



#### WARNING

Battery posts, terminals and related accessories contain lead and lead compounds, chemicals known to the State of California to cause cancer and reproductive harm. Wash hands after handling.



#### CAUTION

Disconnecting battery cables when vehicle is equipped with power door locks will result in automatic locking of doors.



#### WARNING

Always wear eye protection when working around batteries to prevent the risk of injury due to contact with sulfuric acid or an explosion.



#### CAUTION

When using a pressure washer to clean the vehicle, do not direct the spray at electrical components in the engine compartment such as the alternator, starter and compressors. Water spray from pressure washers can damage electrical components.

A maintenance-free battery does not require the addition of water for its normal expected life. Typical features include heavy-duty construction and a wrought lead-calcium grid to resist vibration, shock, overcharge, heat and thermal runaway. Nevertheless, these batteries are vulnerable to the ravages of cold weather operation if totally ignored.

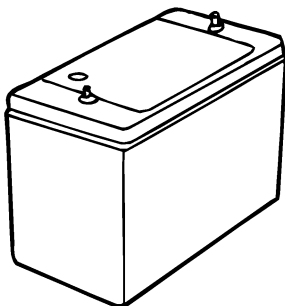

700517a

W0054087

## **40 Operator's Manual Vehicle Maintenance CXU, CHU, GU, TD, MRU and LEU**

---

Be sure that the batteries used in a particular vehicle are rated for the specified Cold Cranking Amperes (CCAs) necessary to ensure reliable cold weather starts. This is important, since even well-maintained batteries chilled to 18 °C (0 °F) may temporarily be capable of providing only 40% of their rated capacity at 27 °C (80 °F).

Keep the terminals clean to prevent formation of power-robbing corrosion.

In winter, to avoid freezing the electrolyte, the battery must be fully charged. A fully discharged battery will freeze solid at 5 °C (23 °F) and possibly sustain permanent damage.

Before the onset of cold weather, be sure to protect this vital component by monitoring its condition as well as inspecting the charging and starting systems.

## Battery Warmer

A battery warmer can be added to raise the temperature of the battery core and facilitate quick starting in cold weather.

## Battery Condition

The first procedure when testing a battery is to check for external damage such as a cracked case, loose or corroded terminals, or signs of excessive gassing or overcharging.

A battery must be fully charged before a load test is performed. Test the battery with a hydrometer to determine the level of charge.

On maintenance-free batteries equipped with a built-in hydrometer (eye), the battery condition is interpreted as follows:

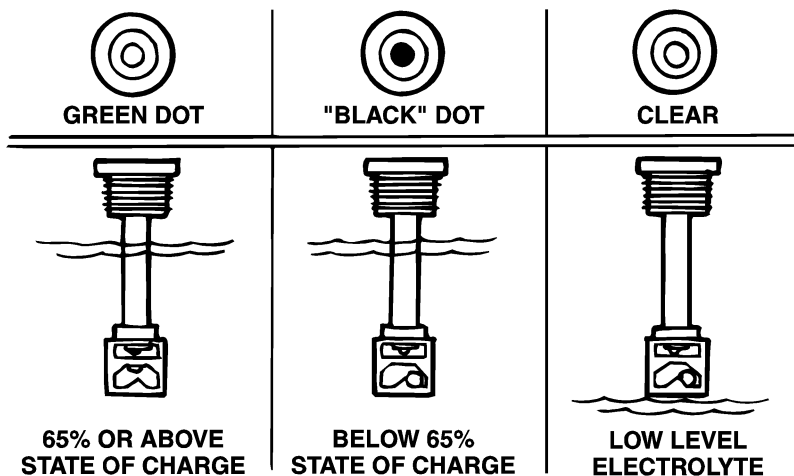

700518a

W005408S

Battery Condition

# 42 Operator's Manual Vehicle Maintenance CXU, CHU, GU, TD, MRU and LEU

- **Green dot visible** Any green appearance should be interpreted as a green dot and means that the battery is at or above a 65% state of charge and is ready for use or testing. This does *not* automatically mean that the battery is in good condition.
- **Dark green dot not visible (black dot)** This indicates that the battery is below a 65% state of charge and must be charged before testing. A black dot does *not* mean that the battery is automatically bad.
- **Clear or light yellow** This means that the electrolyte level is below the level of the built-in hydrometer, which may have been caused by tipping of the battery, a cracked case, or overcharging. This battery should be replaced.

## Charging

Charging should be conducted carefully under controlled conditions. Never charge a frozen battery. If a frozen battery is suspected, thaw it in a warm area for several hours before charging.

The following chart shows the normal charging times necessary to reach a full charge at 26 °C (80 °F). In colder temperatures, the necessary charging time may increase.

Open Circuit Voltage	Battery Specific Gravity*	State of Charge	Charging Time to Full Charge at 80 °F**					
			at 60 amps	at 50 amps	at 40 amps	at 30 amps	at 20 amps	at 10 amps
12.6	1.265	100%	<b>Full Charge</b>					
12.4	1.225	75%	15 min.	20 min.	27 min.	35 min.	48 min.	90 min.
12.2	1.190	50%	35 min.	45 min.	55 min.	75 min.	95 min.	180 min.
12.0	1.155	25%	50 min.	65 min.	85 min.	115 min.	145 min.	280 min.
11.8	1.120	0%	65 min.	85 min.	110 min.	150 min.	195 min.	370 min.
* Correct for temperature.								
** If colder, it will take longer.								

## Completely Discharged Batteries

Extremely cold or completely discharged batteries may not initially show a charge since the electrolyte is nearly pure water and, therefore, a poor conductor. As the acid level in the electrolyte increases during charging, the charging current will also increase. Use the following procedure when charging a completely discharged battery:

- 1 Measure the voltage at the battery terminals. If it is below 10 volts, current will be very low and may not show up on many battery charger ammeters.
- 2 Set the charger on the high setting.
- 3 Some chargers have a polarity protection feature which prevents accidental reversal of the charger leads. A completely discharged battery will not have enough voltage to override this feature, making it appear that the battery will not accept a charge. Check the charger manufacturers instructions on how to bypass this feature.
- 4 Once the battery starts to accept a charge, the charging rate will rise very rapidly. Carefully monitor the ammeter to prevent too-high a charging rate.
- 5 Proceed to charge battery at one-tenth of its rated capacity for one-half hour. Example: For battery rated at 64 (amps-hour), charge at 6.4 amp setting.

**Note:** Batteries with very low voltage (below 11.6 volts) or those that do not initially accept a charge are not necessarily defective. Batteries that have been discharged for long periods of time may be heavily sulfated or hydrated (containing lead shorts that cause the battery to self-discharge). To accept a charge, batteries with either of these conditions may require a longer charging time or a very high initial charge.

Use the following chart to determine the time required for the battery to begin accepting a measurable charge. (If the battery has not started to accept a charge after the specified time, it should be replaced.)

Charger Voltage	Hours
16.0 or more	Up to 4
14.0 to 15.9	Up to 8
13.9 or less	Up to 16

# 44 Operator's Manual Vehicle Maintenance CXU, CHU, GU, TD, MRU and LEU

---

## Load Test

A battery must be fully charged before performing a load test. To load-test a battery that is fully charged, proceed as follows:

- 1 Connect a load tester and voltmeter across the battery terminals.
- 2 Apply a load so that a figure of 300 amps is obtained for 15 seconds to remove the battery surface charge.
- 3 Wait 60 seconds to let the battery recover and then apply the proper test load to the battery to determine its condition. To get the proper load, use half the cranking performance rating. Read the voltage after 15 seconds. Remember that the minimum voltage varies according to temperature. Consult the following chart for the proper specification. If the battery voltage does not fall below the minimum test voltage after 15 seconds, the battery is acceptable for use.

Load Test Temperature Correction		
Minimum Voltage	Temperature	
	C	F
9.6	21	70
9.5	16	60
9.4	10	50
9.3	4	40
9.1	1	30
8.9	7	20
8.7	12	10
8.5	18	0

## Electrical Connection Protection

If corrosion is seen at any external ring-type terminal connections, such as those used at the starter, alternator, chassis and/or engine grounds, etc., LPS HardCoat Corrosion Protectant must be applied to the connection after disconnecting, cleaning and reconnecting the ring terminal. Additionally, LPS HardCoat should be applied to any ring-type terminal connector following any type of service procedure which involved disconnecting/reconnecting the ring terminals (such as component replacement, troubleshooting, service and repair, etc.).



## Wiring Harness/Cable and Connector Protection

To help protect your vehicle's external high amperage electrical cables and connections from corrosion due to the effects of newer salts (calcium chloride and magnesium chloride) on the roadways, MACK is offering a corrosion inhibitor part 20916273 for purchase through the PDC.

MACK recommends coating all high amperage (positive and ground) exposed electrical connections at a minimum of every 6 months or, whenever the connector has been disassembled. The following list contains the recommended connections that should be liberally coated with the corrosion inhibitor;

- Battery connections
- Battery main shut off switch connections
- Maxi and/or Mega fuse connections
- All ground stud connections
- Electrical pneumatic pass-thru connections
- All alternator connections
- All starter connections
- Intake preheater and preheater relay connections
- Electrical power inverter connections

All connections should be cleaned and free of previously applied inhibitors, oil, dirt, dust or other contaminants prior to application. Allow time for the product to dry before use (drying time may vary depending temperature, humidity, etc.).

For more information regarding this corrosion inhibitor produced by LPS Worldwide, visit their web site at [www.lpslabs.com](http://www.lpslabs.com).

## 46 Operator's Manual Vehicle Maintenance CXU, CHU, GU, TD, MRU and LEU

---

### Lighting



#### **WARNING**

Using incorrect bulbs or lamps may result in failures that could lead to a fire or a vehicle accident caused by improper lighting.

Check all lights on the vehicle daily for proper function. Replace burned out inserts and bulbs. Replace any broken or cracked side or rear reflectors. Headlights should be checked for aim at least once per year.

## Precautions When Installing Electrical Equipment

Connecting electrically powered or electrically controlled equipment to a vehicle may cause interference with other vehicle electrical or electronic equipment (such as ABS systems, Rollover Stability Systems, etc.). The amount of interference depends upon the operating frequency of any new signals and the degree to which transient signals are coupled to the vehicle system.

**Note:** Whenever new electrical equipment is installed, it is the obligation of the installer to ensure that the new equipment does not interfere with the proper operation of all other electrical systems on the vehicle.

If new electrical equipment is installed, a vehicle checkout procedure should be performed.

- 1 Perform the checkout procedure under the following conditions:
  - Engine running
  - Brake system air pressure in operating range
  - Vehicle stationary
  - Brake pedal fully depressed
- 2 Operate the new equipment under all starting, running and shutdown conditions.
- 3 Listen for signs of air exhausting from the ABS modulator valves (which is an indication of an interference condition).
- 4 Correct all interference conditions before operating the vehicle.

**Note:** The center pin of the standard seven-pin trailer electrical connector has been standardized as the dedicated connection for uninterrupted power for trailer ABS. This pin is always hot when the tractor ignition is turned on.



### DANGER

Some trailers manufactured prior to the trailer ABS regulations may use the center pin to power certain trailer auxiliary equipment. The possibility exists that this auxiliary equipment may be unexpectedly activated by the truck or tractor electrical system, resulting in personal injury or damage to equipment. Caution must be used when connecting the trailer electrical connector to ensure that power to the center pin will not unintentionally activate any trailer auxiliary equipment.

# 48 Operator's Manual Vehicle Maintenance CXU, CHU, GU, TD, MRU and LEU

---

## MACK Road Stability Advantage

The MACK Road Stability Advantage (RSA) is an available option on certain MACK highway tractors and straight trucks. The RSA system, which is based on the Bendix ABS-6 Advanced with ESP (Electronic Stability Program) System, aids the operator in maintaining control of the vehicle during jackknife or rollover events by applying select brakes and reducing engine power as required by the specific situation. This system is integral with the anti-lock brake system and uses the standard ABS components (such as wheel speed sensors and modulator valves). Additionally, a steering angle sensor and a yaw rate/lateral acceleration sensor package provides information concerning vehicle movement to the electronic control unit.

Before delivery to the end user, a parameter set tuned for the specific vehicle and the VIN for the chassis are loaded into the ABS electronic control unit. This ensures optimal performance of the MACK RSA system for the specific vehicle.

Alterations and modifications to an RSA-equipped vehicle, such as wheel base changes (either lengthening or shortening), the addition of an auxiliary lift axle or the removal of a factory-installed lift axle, or major body changes, such as conversion of a tractor to a truck or an axle, suspension or steering system component modification, are NOT allowed, as these changes will adversely affect performance of the road stability system. Should such changes be unavoidable, the system must be disabled by having a qualified technician replace the Bendix Advanced EC-60 (ABS control unit with ESP) with a Bendix Premium EC-60 ECU (ABS control unit without ESP).

### DANGER

Failure to disable the RSA system on a vehicle that has been modified or altered will result in serious vehicle braking and performance issues, including unnecessary system interventions.

These interventions could lead to a loss of vehicle control.

In addition to disabling the system, any cab labels, such as warning and caution labels relating to the Bendix ABS-6 Advanced with ESP system located on the sun visor must be removed, and notations must be made in the operators manuals so that the vehicle operator has a clear understanding as to which ABS options are installed on the vehicle.

The location of the yaw rate/lateral acceleration sensor must not be altered.

Aftermarket steering wheels must not be used. Only OEM-supplied replacement steering wheels should be used. During any procedure that involves removal and reinstallation or replacement of the OEM steering wheel, care must be used not to crush or damage the steering angle sensor which is mounted on the steering column.

Increasing steering angle beyond maximum is NOT permitted. However, steering angles may be increased to the maximum factory settings if required. Refer to the applicable steering system service manual for detailed information.

The steering angle sensor must be recalibrated following any adjustments or changes to the steering system.

Changing steer axle and/or drive axle track width is permissible.

Changing front or rear axle brake drums to drums having a different flange thickness is permissible.

The ABS with ESP ECU requires a precise rolling circumference ratio between the front steer axle and the rear drive axles for optimum performance of the system. For this reason, the system continuously calculates the precise ratio and stores the information in the ECU memory.



## CAUTION

Effectiveness of the RSA system relies on the accuracy of the reported vehicle speed. If major changes to tire sizes are made, such that changes to the vehicle speedometer/odometer settings are required, the ABS with ESP ECU must be reprogrammed with the new values by a qualified technician.

## Engine Storage

### Engine Storage

If the vehicle must be parked for a period (more than 30 days), protect it as follows:

- 1 Drain the engine oil.
- 2 Fill up to the proper level with oil of the recommended quality and viscosity.
- 3 Fill up the fuel tanks with the recommended grade of fuel.
- 4 Run the engine for two minutes around 1000 rpm. Shut the engine down. DO NOT drain the oil after this run.
- 5 Check the coolant for proper levels of antifreeze and inhibitor (SCA) protection. Service as necessary.
- 6 Seal all engine openings using protective covers.

To return to service an engine preserved in this manner, remove previously installed protective covers. Check all fluid levels and if necessary replace engine oil contaminated by condensation.

## Maintenance and Service

### Maintenance Hazards



#### DANGER

Before working on or inspecting a vehicle, set the parking brakes, place the transmission in neutral and chock the wheels. Failure to do so can result in unexpected vehicle movement and can cause serious personal injury or death.



#### DANGER

DO NOT attempt to repair or service this vehicle without having sufficient training, correct service literature and the proper tools. Failure to follow this could lead to personal injury or death, or making your vehicle unsafe.

**Note:** Read all safety information before working on the vehicle.

### Engine Components, Service Schedules

Component	Operation	Km (Miles)/Maximum Months/Hours
Fuel Filter (MP7, MP8 and MP10)	Change	Each oil change*
Water Separator (MP7, MP8 and MP10)	Filter change	Each oil change*
Air Filter EPA 2010	Change	160 000 (100,000) or 12 months, whichever comes first
Air Filter Euro 4	Change	At maximum restriction as indicated on gauge, or 12 months
Coolant (MP7, MP8 and MP10)	Change	500 000 (300, 000) 6000 or 24 months, whichever comes first
Coolant, Extended Life (ELC) (MP7, MP8 and MP10)	Change	1 000 000 (600,000) or 48 months, whichever comes first

## 52 Operator's Manual Vehicle Maintenance CXU, CHU, GU, TD, MRU and LEU

Component	Operation	Km (Miles)/Maximum Months/Hours
Coolant Filter (MP7, MP8 and MP10)	Change	80 000 (50,000) or 6 months, whichever comes first
Coolant Filter, Extended Life (ELC) (MP7, MP8 and MP10)	Change	240 000 (150,000) or 12 months, whichever comes first (MP7, MP8 and MP10)
Coolant Conditioner Euro 4	Change	Traditional coolants requiring Supplemental Coolant Additive (SCA) 80 000 (50,000) or 6 months
Valves/Injectors (MP7 and MP8)**	Initial Adjust	200 000 (125,000) or 12 months, whichever comes first
Valves/Injectors (MP7 and MP8)**	Adjust	400 000 (250,000) or 24 months, whichever comes first
Valves/Injectors (MP10) **	Initial Adjust	100 000 (60,000) or 6 months, whichever comes first
Valves/Injectors (MP10) **	Adjust	200 000 (125,000) or 12 months, whichever comes first
Drive Belts CXU, CHU and TD Euro 4 (Highway)	Change	500 000 (300,000) or 36 months, whichever comes first
Drive Belts GU, LEU and MRU Euro 4 (Vocational)	Change	240 000 (150,000) or 12 months, whichever comes first
Catalyzed DPF Filter (If equipped) (MP7, MP8 and MP10)	Change	240 000 (150,000) or 4,500 hours, whichever comes first
Aftertreatment Doser (If equipped) (MP7, MP8 and MP10)	Clean	240 000 (150,000) or 4,500 hours, whichever comes first



# Operator's Manual Vehicle Maintenance CXU, CHU, GU, TD, MRU and LEU 53

Component	Operation	Km (Miles)/Maximum Months/Hours
Diesel Exhaust Fluid (DEF) Pump Filter (MP7, MP8 and MP10)	Change	First Change; 161 000 (100,000) or 3200 hours, whichever comes first 241 000 (150,000) or 4800 hours or three (3) years, whichever comes first
Diesel Exhaust Fluid (DEF) Tank Filler Neck Filter Cleaning (MP7, MP8 and MP10)	Clean	280 000 (175,000) or 12 months, whichever comes first
*Under certain conditions (for example, irregular fuel quality), the fuel/water separator filters may require more frequent replacement.		
**Valves must be adjusted whenever the rocker shaft has been removed and reinstalled for any reason.		

## Cooling System

### General Coolant Information



#### **DANGER**

Coolant is toxic; risk of poisoning. **DO NOT** drink coolant. Use proper hand protection when handling. Keep coolant out of reach of children and animals. Failure to follow these precautions can cause serious illness or death.



#### **WARNING**

**DO NOT** raise the engine hood if you see or hear steam or coolant escaping from the engine compartment. Wait until steam or coolant cannot be seen or heard before raising the hood.

**DO NOT** remove the coolant fill cap if the coolant in the surge tank is boiling. Also, **DO NOT** remove the cap while the engine and radiator are still hot. Scalding fluid and steam may be blown out under pressure if the cap is taken off too soon and can cause personal injury.



#### **WARNING**

Coolant may be combustible. Coolant leaked or spilled onto hot surfaces or electrical components can cause a fire. Clean up coolant spills immediately.



#### **CAUTION**

MACK Inc. does not recommend using plain water in the cooling system. Water alone is corrosive at engine operating temperatures and does not provide adequate boiling protection. The engine may develop corrosion and cavitation problems in the engine and radiator, and the boiling point of the coolant is lowered compared to a proper antifreeze and water mixture. Failure to follow MACK Inc. cooling system care/maintenance recommendations can render the warranty invalid.

The cooling system plays an important role in overall engine performance by keeping the engine within the normal operating temperature range hot enough for efficient combustion, and cool enough to prevent engine damage caused by overheating. Good preventive maintenance practices, along with monitoring cooling system performance, go a long way in preventing engine damage that could result from cooling system problems. The maintenance items and tests outlined in this section should be performed at the intervals specified to ensure optimum performance from the cooling system.

## Surge Tank Cap

MACK conventional models (CXU, CHU, GU and TD) utilize a coolant surge tank mounted on top of the radiator. The surge tank has a fill cap located on the top right-hand side of the tank, and a pressure cap rated at 16 lb. which incorporates an overflow tube located on the left-hand side of the tank. Check the coolant level regularly, making sure the coolant level is between the COLD MIN and COLD MAX lines on the back of the tank. At each C and D inspection interval, inspect the rubber gaskets on each of the caps. Replace the cap(s) if the gaskets show evidence of damage which could affect sealing.



### WARNING

DO NOT remove the fill cap while the cooling system is hot. Allow the system to cool sufficiently before removing. Turn the fill cap slowly counterclockwise and wait for the pressure in the system to dissipate. After the pressure has dissipated, completely remove the cap.

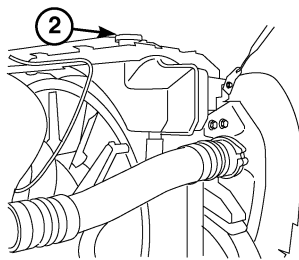
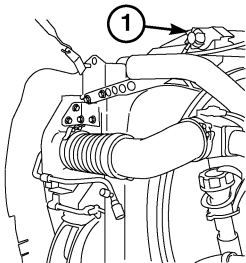

273225a

W0054042

### Surge Tank Conventional Models

1. Pressure Cap	2. Fill Cap
-----------------	-------------

## 56 Operator's Manual Vehicle Maintenance CXU, CHU, GU, TD, MRU and LEU

---

MACK low cab forward models (MRU, LEU) utilize a surge tank which is located on the left-hand side of the chassis, mounted on a stanchion to the rear of the cab. This surge tank utilizes a standard radiator pressure cap. Check the coolant level regularly, making sure the coolant is visible in the sight glass located on the side of the tank.

At each C and D inspection interval, remove the radiator cap and inspect the gasket for any defects that would affect sealing. Also, pressure-test the cap using a suitable cooling system and radiator cap tester. Surge tank cap pressure specifications are as follows:

- MP7 Engines (MRU and LEU Models) 16-lb. pressure cap
- MP8 Engines (MRU Models only) 16-lb. pressure cap



### WARNING

DO NOT remove the fill cap while the cooling system is hot. Allow the system to cool sufficiently before removing. Turn the fill cap slowly counterclockwise to the first stop, and then wait for the pressure in the system to dissipate. After the pressure has dissipated, completely remove the cap.

The main purpose of coolant is to transport heat from the hot parts of the engine to the radiator and to protect the cooling system from corrosion.

In addition to this, the coolant must:

- Protect against pitting and cavitation erosion damage of the water pump and cylinder liners.
- Protect against freezing and boiling.
- Prevent formation of scale, sludge deposits and clogging.
- Be harmless to polymer materials and seals in the cooling system.
- Maintain its liquid properties in cold climates.

Many engine failures can be traced back to a problem in the cooling system. If the coolant level is allowed to go below the bottom of the tank, there is the risk of the engine shutting down. See the operators manual for more information on the warning functions.

**Note:** Always dispose of coolant according to Federal or local regulations. Take all used coolant to a recycling or waste collection center.

Coolant mixture consisting of an antifreeze solution in water should be used year-round to provide freeze and boil-over protection as well as providing a stable environment for seals and hoses.

**Note:** DO NOT use antifreeze formulated for automobile gasoline engines. These have a very high silicate content that will clog the radiator and leave unwanted deposits in the engine.

## *Coolant System Capacities*



### **CAUTION**

Capacities may vary due to hoses and size of radiator, as well as accessory cooling equipment. After running the engine until normal operating temperature is reached, check the coolant level and add coolant as needed.

Use the chart shown in conjunction with the Ethylene-Glycol and Propylene-Glycol Protection Charts in this section to determine the amount of antifreeze needed to protect your vehicle.

## 58 Operator's Manual Vehicle Maintenance CXU, CHU, GU, TD, MRU and LEU

Chassis Model	Engine Model	Coolant Capacity in Liters (Quarts)
CXU	MP7* MP8*	52 (55) 54 (57)
CHU	MP7* MP8*	52 (55) 54 (57)
TD7	MP10*	53 (56)
GU7	MP7* MP8*	52 (55) 54 (57)
GU8	MP7* MP8*	52 (55) 54 (57)
MRU	MP7 Manual transmission without auxiliary cooling package MP7 Manual transmission with auxiliary cooling package MP7 Automatic transmission without auxiliary cooling package MP7 Automatic transmission with auxiliary cooling package MP8**	39 (41) 48 (51) 48 (51) 58 (61) 52 (55)
LEU***	MP7 Automatic transmission without auxiliary cooling package MP7 Automatic transmission with auxiliary cooling package	48 (51) 58 (61)

\* Coolant capacities listed are for chassis equipped with manual transmissions. For automatic transmissions, add 9.5 liters (10 qts).

\*\* Allison automatic transmission is not an available option for MRU models equipped with an MP8 engine.

\*\*\* LEU models are not available with a manual transmission.

Use the following antifreeze protection charts to determine the percentage of antifreeze needed to achieve specific protection levels for various coolant systems.

## Ethylene-Glycol Protection Chart

Ethylene Glycol	Ambient Air Temperature
40%	24 °C (12°F)
50%	37 °C (34 °F)
60%	52 °C (62 °F)

## Propylene-Glycol Protection Chart

Propylene Glycol	Ambient Air Temperature
40%	21 °C (6 °F)
50%	33 °C (27 °F)
60%	49 °C (56 °F)

A well functioning and maintained cooling system is as important to the engine as performing regular oil changes or using good fuel. To get the best result use quality products and service the system at the correct intervals. Please read this section carefully.

Keep the radiator (including charge air cooler) and the frontal area free from bugs, dirt, leaves, etc. (see “Cleaning Charge Air Cooler and Radiator Package”, page 107 for cleaning information).

Check the coolant level in the tank regularly. Fill the tank as necessary with the correct coolant.

## 60 Operator's Manual Vehicle Maintenance CXU, CHU, GU, TD, MRU and LEU

---

Inspection of the whole cooling system is important. Check for swollen or deteriorated heater and radiator hoses, loose hose clamps and connections, and radiator leaks.



### DANGER

DO NOT work near the fan with the engine running. The engine fan can engage at any time without warning. Anyone near the fan when it turns on could be seriously injured. Before turning on the ignition, be sure that no one is near the fan.



### CAUTION

Never add coolant to a hot or overheated engine. Engine damage can result. Allow the engine to cool first.

### *Additives*

Additives help prevent rust, scale and mineral deposits from forming. Additives also protect metals from corrosion, prevent water pump and cylinder liner cavitation and contain anti-foaming agents. Additives are depleted during normal engine operation and need to be **replaced**. For non-extended life coolant mixture, this means the addition of **Supplemental Coolant Additives (SCA)** at any time the additive goes below the recommended level. For extended life coolant mixture, this means an extender package added halfway through the coolant lifetime.



## **Regular Coolant Change Interval**

Coolant SCA level must be tested at least twice per year or whenever coolant loss occurs. For maximum coolant system efficiency, test the system at every engine oil change interval, every 1,000 hours or every 6 months (whichever comes first). For proper SCA levels, consult Service Manual.

### *Regular Coolant Filter Change Intervals*



#### **WARNING**

Hot engine. Keep clear of all hot engine parts and fluids. A hot engine and fluids can cause serious burns.

The charged coolant filter contains 8 units of SCA that are released slowly over time to maintain the recommended level during operation. Consult engine service manual for proper SCA level and change intervals.

## 62 Operator's Manual Vehicle Maintenance CXU, CHU, GU, TD, MRU and LEU

---

### Extended Life Coolant Change Interval



#### CAUTION

Extended life coolant will test as out of additives (SCA), but SCA should not be added. Shortened engine life may be the result of adding SCA.

**Note: DO NOT add supplement coolant additives (SCA) to extended life coolant.**

Should the extended life coolant system become contaminated with regular coolant exceeding 10% of the systems total capacity or if SCA is added to extended life coolant, drain the system and refill with new extended life coolant or regular coolant.

### *Extended Life Coolant Filter Change Interval*



#### WARNING

Hot engine. Keep clear of all hot engine parts and fluids. A hot engine and fluids can cause serious burns.



#### CAUTION

DO NOT use a filter that contains SCA. Damage to components can result.

## Fuel System

### Fuel Safety Reminders



#### **DANGER**

A diesel engine will operate on any fuel which enters the cylinder, whether it is from the injectors or from the air intake system. Therefore, if any solvent is used to flush out the air cleaner element, the engine may over speed during start-up. Engine damage, severe personal injury or death from burns or explosion may occur.



#### **DANGER**

DO NOT mix gasoline or alcohol with diesel oil fuel. This mixture can cause an explosion and result in severe personal injury or death.



#### **DANGER**

DO NOT remove the fuel tank cap near an open flame. Diesel fumes are combustible and can cause an explosion or fire resulting in severe personal injury or death.



#### **WARNING**

If a fuel leak is detected, stop the engine immediately. The vapors from hot fuel are highly flammable which may result in a fire.



#### **WARNING**

DO NOT store fuel containers in the vehicle. They may leak, explode and cause or feed a fire. Empty or full, they present a hazard that may lead to burns in the event of a fire.

# 64 Operator's Manual Vehicle Maintenance CXU, CHU, GU, TD, MRU and LEU

---

## Diesel Fuel Specification

### Quality



#### CAUTION

Diesel engines for 2007 and later model year vehicles are designed to operate only with Ultra Low Sulfur Diesel (ULSD) fuel. Use of fuel other than ULSD will reduce the efficiency and durability of the engine, permanently damage the advanced emission control systems, reduce fuel economy and possibly prevent the engine from running at all. Manufacturers warranties are likely to be rendered void by usage of improper or incorrect fuel, and usage of fuels other than ULSD fuel in diesel-powered vehicles is illegal and punishable with civil penalties. Use of fuel additives to compensate for the lower sulfur content is NOT recommended by MACK Inc.

The proper selection of fuel is essential for good economy, performance and engine life. No. 2D ULSD should be used when climatic conditions permit. No. 1D ULSD can be used during cold weather conditions. Blends of No. 1D and No. 2D ULSD fuels can be used to suit various climatic conditions.

**Note:** The use of lighter fuels (grade No. 1-D) can reduce fuel economy.

#### **Note: Euro 4 Engines**

Ultra Low Sulfur Diesel (ULSD) fuel with a maximum sulfur content of 15 ppm is required to meet emission certification for Euro 4 emission engines. Using approved diesel fuel with a maximum sulfur content of 500 ppm in Euro 4 emission engines will meet all reliability standards.

The fuels used must be clean, completely distilled, stable and non-corrosive. Always try to keep the fuel tank full. DO NOT put alcohol into the fuel tank. Fill the tank after completing driving for the day.

### Fuel Sulfur Content

Fuel sold for use in diesel-powered engines for 2007 and later model year vehicles may only contain a maximum sulfur content of 0.0015% by weight. This was done to reduce particle emissions in the exhaust.

**Note:** The use of ultra-low sulfur diesel fuel does not permit extension of engine oil change intervals or oil filter changes.

## *Cetane Number*

Direct injected diesel engines require a minimum cetane number of 43 under normal starting conditions. Fuel with a higher cetane value may be required for high-altitude or cold-weather operation.

## *Filtration*

Fuel should be clean and free of contamination. Clean fuels should have no more than 0.05% of sediment and water.

## *Fuel Additives*

Fuel additives are generally not recommended or needed for fuels listed earlier. Cetane improvers can be used as necessary. Biocides may be needed to eliminate microorganism growth in storage tanks. In cold conditions, treatment for water in the vehicle tanks may also be necessary.

Consult your fuel supplier about the use of additives to prevent incompatibility among additives already in the fuel and the additives to be used.

## *Supplemental Fuel Enhancers*



### **CAUTION**

Supplemental additives are not recommended because of a high risk of injection system problems or engine damage.

There are many aftermarket products available today which are intended to be added by the customer. They generally increase operating cost without providing benefits. Included are a variety of independently marketed products which claim to be:

- Cetane improvers
- Emission control additives
- Detergents
- Combustion improvers
- Smoke suppressants
- Cold weather flow improvers

**Note:** Repair expenses resulting from malfunctions in the fuel system or with engine components when fuel enhancers have been used are not covered under warranty.

## 66 Operator's Manual Vehicle Maintenance CXU, CHU, GU, TD, MRU and LEU

---

Some fuel additives can be used to provide temporary relief, but they do not replace good fuel handling practices. These products can be used:

- Isopropyl Alcohol Use 1/2 liter per 450 liters (1 pint per 125 gallons) of fuel for winter freeze-up protection.
- Biocide For treatment of microbe growth or black slime. Follow manufacturers instruction for treatment.

### *Prohibited Additives*



#### **WARNING**

The addition of gasoline to diesel fuel will create a serious fire hazard. Serious personal injury can result.

The following additives are specifically NOT allowed and must NOT be mixed in with the vehicle diesel fuel:

- Gasoline Adding gasoline to diesel fuel will reduce the cetane number and increase combustion temperature. If a tank contains a diesel fuel/gasoline mixture, it should be drained and cleaned as soon as possible.
- Used lubricating oil MACK Inc. does not recommend the use of any type of used lubricating oil as an extender in the diesel fuel. Used lubrication oil contains solids and acids from the combustion process that can severely corrode parts of the injection system, resulting in reduced power and higher maintenance cost over time.

### *Alternative Fuels*

Alternative fuels can be of several different types. There are vegetable based fuels, aviation fuel and recycled petroleum based fuels that are used in combustion engines. These are in general not compatible with modern heavy-duty over-the-road diesel engines.

The use of unauthorized fuels may compromise the levels of pollutants in the exhaust to the point where the engine does not meet the emission requirements. This would make the vehicle illegal to drive on public roads. DO NOT use any kind of alternative fuel unless specifically authorized by MACK Inc.

## Bio Diesel

The only Bio Diesel Fuel approved by MACK Inc. for use in EPA 2010 MACK Engines is Soy Methyl Ester (SME or SOME) in blends up to B5 Concentration (5% blend).

**Note:** Although higher concentrations are available, concentration up to B5 (maximum) are the only blends currently approved by MACK Inc.

## *Fuel Storage*

If fuel is stored on site:

- Keep storage tank covered to prevent water entry.
- DO NOT use a tank made of galvanized metal or any galvanized piping for diesel oil storage. Diesel will react with the zinc, forming solids that can clog fuel filters and cause engine damage.
- Fuel stored for a long time may oxidize and form solids, causing filtering problems.
- Keep the area around the fill cap clean. Tilt the tank slightly toward the drain plug area so water and sediment can be easily drained.

Generally, fuel contamination occurs as the result of improper fuel handling. The most common types of contamination are water, dirt and microbial growth (black slime). The formation of varnishes and gums resulting from poor fuel stability or long storage (stale fuel) also affects fuel quality. The best treatment for contamination is prevention by maintaining a clean storage system and choosing a reputable fuel supplier.

# 68 Operator's Manual Vehicle Maintenance CXU, CHU, GU, TD, MRU and LEU

## Fuel Filters

A primary fuel filter can be located on the engine or remote mounted on the frame rail. This filter consists of a filter cartridge, a water separation bowl and may have a fuel heater built in.

The secondary fuel filter is located on the left hand side, below the engine electronic control unit (EECU). The filter is a spin-on filter.

MACK MP engines utilize a spin-on primary and secondary fuel filters. Both filters are located on the right-hand side of the engine.

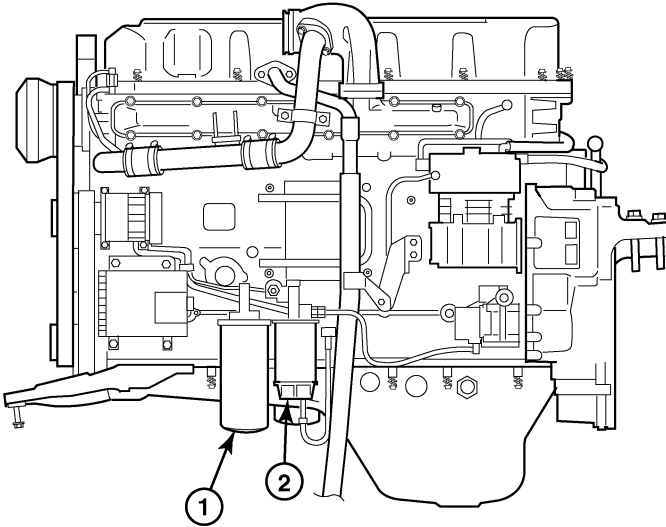

270540a

W0054019

Fuel Filters MACK MP Engine

1. Secondary Fuel Filter	2. Primary Fuel Filter
--------------------------	------------------------

The primary fuel filter on MACK MP engines incorporates a plastic water separator bowl. Additionally, the plastic bowl includes a water-in-fuel sensor. A warning lamp on the instrument panel illuminates when water is detected in the fuel. Refer to Fuel/Water Separator section.

**Note:** There are optional fuel filter systems (such as Davco, Conmet, etc.) available for MACK MP engines. These fuel filter systems use a single remote-mounted filter, eliminating the spin-on primary and secondary filters. For service information concerning these filters, refer to the specific fuel filter manufacturers service literature.



## Primary Fuel Filter Replacement Procedures MACK MP Engines

At each specified oil and filter change interval, change the primary fuel filter as follows:

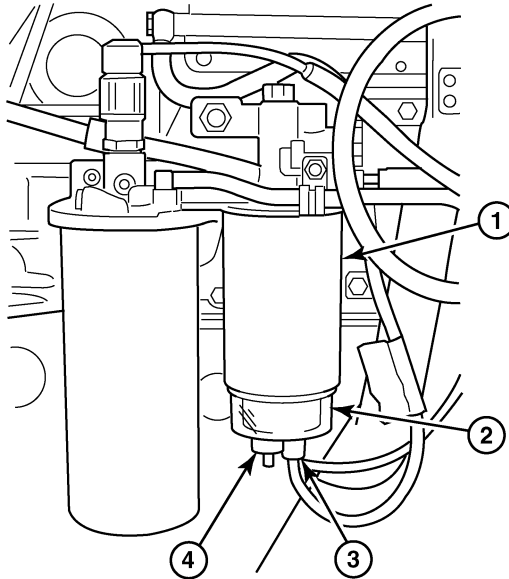

270620a

W0054023

MACK MP Primary Fuel Filter

1. Primary Filter	3. Water-in-Fuel Sensor Harness
2. Water Separator Bowl	4. Drain Assembly

## 70 Operator's Manual Vehicle Maintenance CXU, CHU, GU, TD, MRU and LEU

---

- 1 Thoroughly wash the area around the fuel filter and mounting adapter mating area with a suitable solvent and blow dry with compressed air.
- 2 Disconnect the water-in-fuel sensor harness connector from the plastic water separator bowl.
- 3 Using tool J 24783, remove the primary filter.
- 4 While holding the filter above a suitable container, open the drain valve on the plastic water separator bowl and allow the fuel in the bowl to drain. Dispose of the drained fuel in an environmentally safe manner.
- 5 Unscrew the plastic separator bowl from the bottom of the spin-on primary filter cartridge.
- 6 Apply a thin film of clean engine oil to the water separator bowl O-ring on the bottom of the **new** primary filter cartridge.
- 7 Install the plastic water separator bowl to the primary filter cartridge, and tighten the bowl by hand 1/4 to 1/2 turn after the bowl contacts the O-ring.
- 8 Apply a thin film of clean engine oil to the sealing gasket of the **new** filter cartridge.
- 9 Prime the filter by pouring clean filter fuel through the series of small holes at the top of the filter to the installation fill line. **DO NOT** prime the filter through the center hole. Use care to avoid dirt entering the center hole of the filter.
- 10 Install the **new** filter and tighten an additional 1/2 to 3/4 turn by hand after the gasket contacts the base.
- 11 Reconnect the water-in-fuel sensor harness connector.
- 12 Prime the engine as required prior to starting the engine (refer to “Priming the Fuel System MACK MP Engines”, page 72).
- 13 Start the engine and check for leaks.

## Secondary Fuel Filter Replacement Procedures

At each specified oil and filter change interval, change the secondary fuel filter as follows:

**Note:** Because of ice buildup in the fuel system or fuel waxing which can clog fuel filters, it may be necessary to reduce the time or mileage interval between fuel filter changes during extremely cold weather.

To install a new filter:

- 1 Thoroughly wash the area around the fuel filter and mounting adaptor mating area with a suitable solvent and blow dry with compressed air.
- 2 Using tool J 24783, remove the old filters.
- 3 Apply a thin film of clean engine oil to the sealing gasket of the new filters.
- 4 Prime the filter by pouring clean filtered fuel through the series of small holes at the top of the filter. DO NOT prime the filter through the center hole. Use care to avoid dirt entering the center hole of the filter.
- 5 Install the **new** filters and tighten an additional 3/4 to 1 turn by hand after the gasket contacts the base.
- 6 Prime the engine as required prior to starting the engine (refer to “Priming the Fuel System MACK MP Engines”, page 72).
- 7 Start the engine and check for leaks.

## 72 Operator's Manual Vehicle Maintenance CXU, CHU, GU, TD, MRU and LEU

### Priming the Fuel System MACK MP Engines

On MACK MP engines, the priming pump is located on the primary fuel filter mounting adapter. Prime the fuel system as follows:

#### DANGER

Before working on or inspecting a vehicle, apply the parking brakes, place the transmission in neutral and block the wheels to prevent the vehicle from moving. Failure to do so can result in unexpected vehicle movement and cause severe personal injury or death.

#### WARNING

DO NOT work near the fan while the engine is running. The engine fan can engage at any time without warning, resulting in serious injury. Before turning the ignition on, make sure that no one is near the fan.

#### DANGER

To avoid potential fire hazard, do not service any part of the fuel system while smoking, or in the presence of flames, sparks or hot surfaces. Do not service the fuel system while the engine is running. Failure to follow these precautions can result in a fire. To guard against burns from direct contact with hot fuel, wear adequate protective clothing (face shield, heavy gloves, apron, etc.) when working on a hot engine.

**Note:** There are NO bleed nipples that must be opened in order to prime the fuel system.

# Operator's Manual Vehicle Maintenance CXU, CHU, GU, TD, MRU and LEU 73

---

- 1 Unlock the primer pump handle by pushing the handle downward and then turning it counterclockwise.

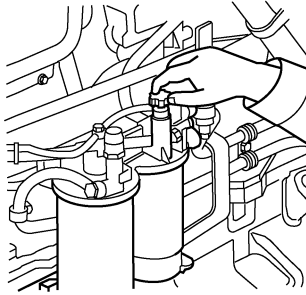

270986a

W0054026

## Unlocking Fuel System Primer Pump Handle

- 2 Operate the pump handle until pumping effort increases.

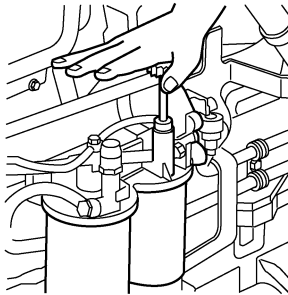

270987a

W0054027

## Pumping Hand Primer Pump

**Note:** With a fuel system that is completely empty, 200 or more strokes of the pump may be necessary to properly prime the system.

- 3 When the fuel system is primed, lock the primer pump handle by pushing it fully into the housing and turning it clockwise.
- 4 Start the engine and run it at 1000 rpm for approximately 5 minutes to purge any remaining air from the system.

**Note:** If the engine does not start after performing the above priming procedure, contact your local MACK dealer for assistance.

# 74 Operator's Manual Vehicle Maintenance CXU, CHU, GU, TD, MRU and LEU

## Fuel/Water Separator MACK MP Engines

The primary fuel filter on MACK MP engines includes a plastic water separator bowl with an integral water-in-fuel sensor and a drain assembly. A warning lamp on the instrument panel illuminates when water is detected in the fuel. When the lamp illuminates, drain the water from the separator by opening the drain valve and allowing the water to drain from the bowl into a suitable container. When fuel begins to drain, close the valve and tighten to 0.655 Nm (5 lb-in). Dispose of the drained water/fuel in an environmentally safe manner.

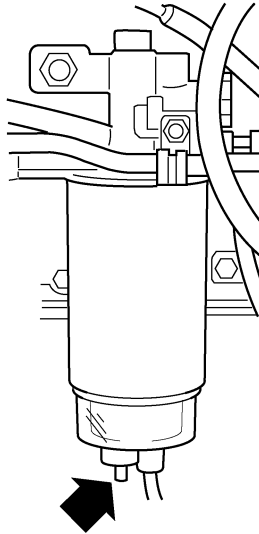

270618a

W0054022

Water Separator Drain Valve MACK MP  
Engines

**Note:** DO NOT drain the water separator bowl while the engine is running.

## Engine Oil

### General

Keep the engine oil at the proper level and change it at the recommended intervals. Always replace the oil filters at the same time as when the oil is changed.

### Oil Quality

MACK Inc. recognizes engine oils that meet or exceed the standards given by American Petroleum Institute (API) for the oil classifications listed in this manual. Only oils licensed to carry the API symbol should be used. Lubricants meeting API standards have provided maximum engine life when used together with the recommended oil and oil filter change intervals.

EO-O Premium Plus (or VDS-4) diesel engine oil is mandatory for use in all 2010 emission compliant MACK engines. Chassis equipped with a 2010 emission compliant engine, which can be identified by the presence of a Diesel Particulate Filter (DPF), also require the use of Ultra Low Sulfur Diesel (ULSD) fuel. EO-O Premium Plus oils exceed the new API service category CJ-4.



#### CAUTION

DO NOT add extra oil additives. Additives such as break-in oils, top oils, graphitizers, and friction-reducing liquids are not necessary and can harm the engine.

### Oil Change Intervals

The length of time an engine can operate before an oil change depends on the quality oil used, the type of fuel used, fuel consumption, engine oil consumption, vehicle application, level of dust in the air, and fuel consumption. The change intervals given in this manual are maximum intervals. If the vehicle is operating in heavy-duty operation, dusty or off-road conditions, etc., reduce the intervals for more frequent oil changes. For the correct oil change interval, see "Oil Capacity Tables and Viscosity Charts", page 142.

For additional information about oil change intervals, see your MACK Truck dealer.

For a complete list of approved oils, see your MACK Truck dealer.

**Note:** Oil filters should always be changed when changing oil.

# 76 Operator's Manual Vehicle Maintenance CXU, CHU, GU, TD, MRU and LEU

## Oil Filters

There are three filters on the engine, one of which is a bypass filter. This should be changed at the same time as the full-flow filter(s).



### CAUTION

MACK branded oil filters are designed to provide the proper level of filtration and protection for MACK engines. Filters that do not meet the same stringent requirements may void engine warranty.

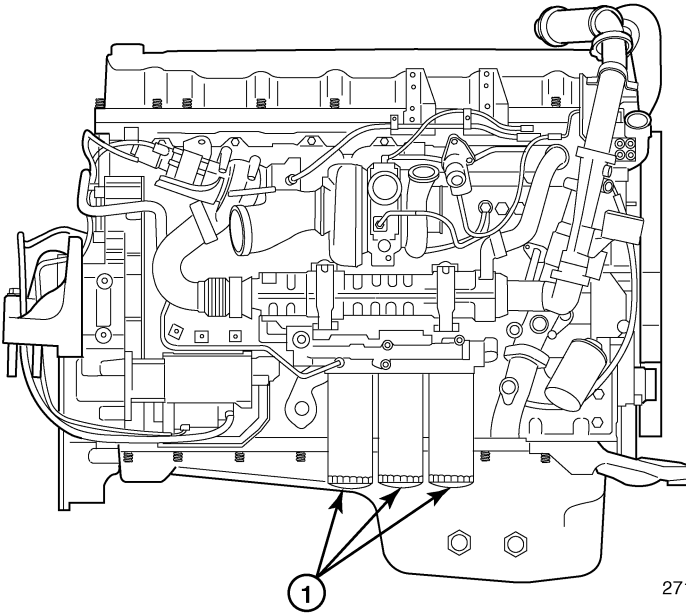

271444a

W0054029

### Spin-On Oil Filters

#### 1. Spin-On Oil Filters



## Synthetic Lubrication

Synthetic oils are offered by some oil suppliers as an alternative to the traditional, petroleum based oils for engines. These oils may be used in MACK engines, provided they meet the quality levels specified on the previous pages, that is: both VDS-4 and EO-O Premium Plus.

**The use of synthetic oils does not permit the extension of the recommended oil change intervals. It is the contamination rate, i.e., soot, and the depletion of additives, rather than base oil quality that determines the useful engine oil life and therefore the oil change intervals.**

## Oil Viscosity

The viscosity grade defines the thickness of the oil. The oil must be thin enough at low temperatures for easy cold starts and thick enough to protect at high temperatures. An oil is not fully defined until both the API quality classification and the viscosity grade are specified.

Choose the viscosity grade for the typical ambient temperature for the application. Multigrade oils have a broad range that suit operation in changing temperature. The standard oil weight for MACK engines is 10W/30.

MACK Inc. recommends the viscosities shown in the viscosity/temperature table for MACK engines.

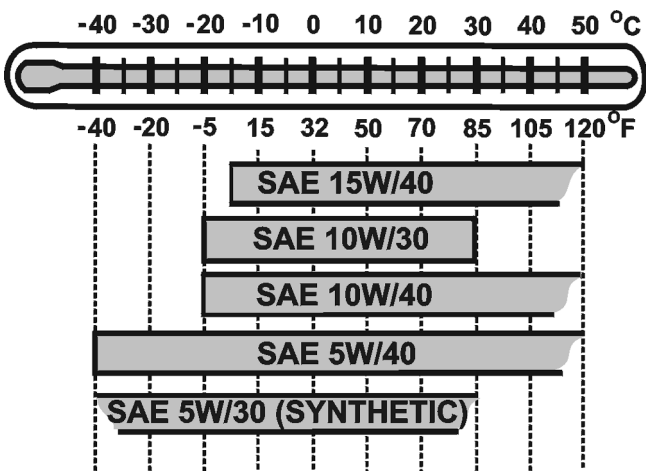

# 78 Operator's Manual Vehicle Maintenance CXU, CHU, GU, TD, MRU and LEU

---

## Oil Additives



### CAUTION

Extra oil additives must never be added to any engine oil used. Additives such as break-in oils, top oils, graphitizers, and friction reducing liquids are not necessary and may even harm the engine.

Using oils to the quality standards recommended in this manual makes the use of extra oil additives unnecessary, as these oils already contain a balanced treatment of additives.

## Oil Consumption

Once the engine is stopped, check the oil level daily. If the engine has just been stopped and it is warm, wait approximately five minutes to allow the oil to drain back to the oil pan before checking. Add oil as necessary.

**Note:** DO NOT overfill engine with oil.

All diesel engines are designed to consume some oil, so it is normal to add oil periodically. An engine used in heavy-duty operation will consume more oil than one in normal operation.

To assist you in measuring your oil usage please refer to the Fuel and Oil Record on “Fuel and Oil Record”, page 155.

## **Oil Change**



### **WARNING**

A hot engine or engine oil can be dangerous. Serious burns can result from contact with a hot engine or oil. Take precautions when draining the oil. Wear gloves or let the engine cool down before draining.



### **WARNING**

When draining the oil, use the proper tools and keep away as far as possible. Raise the elbow so the forearm is parallel to the ground to prevent oil running down the arm, causing burns.



### **CAUTION**

Always dispose of all lubricants (motor oil, coolant, gear box oils, etc.) and filters according to Federal or local regulations. Used oil disposed of in nature or waterways contaminates our drinking water and kills wildlife.



### **CAUTION**

Prolonged contact with used engine oil may be harmful. Use rubber gloves when handling used oil. Wash skin thoroughly if it comes in contact with used oil.

For information on the type of oil recommended for your engine, see “Oil Quality”, page 75 and “Oil Capacity Tables and Viscosity Charts”, page 142 for quantities and viscosities, or refer to the engine manufacturers operators manual.

It is important to drain as much oil as possible. Try to change oil immediately after driving, when the oil is warm. Always replace the oil filters when changing oil.

# 80 Operator's Manual Vehicle Maintenance CXU, CHU, GU, TD, MRU and LEU

---

## Oil Filters Change



### WARNING

Hot oil can cause severe burns. DO NOT allow hot oil to contact the skin. When changing oil, wear protective gloves.



### CAUTION

MACK-branded oil filters are designed to provide the proper level of filtration and protection for MACK engines. Filters that do not meet the same stringent requirements may cause unsatisfactory results.

- 1 Coat the filter gasket with oil.
- 2 Install the filter and turn it by hand until the gasket makes contact with the sealing surface.
- 3 Manually turn the filter an additional 3/4 to one full turn.

## Checking Oil Level



### CAUTION

DO NOT let the oil level fall below the marking on the dipstick. DO NOT overfill so the level is above the upper marking on the dipstick. This could lead to excessive oil temperature and/or poor crankcase breather performance.

Ensure that the vehicle is parked on level ground before checking the oil level. Wait five minutes after shutting off the engine, then proceed with checking oil.

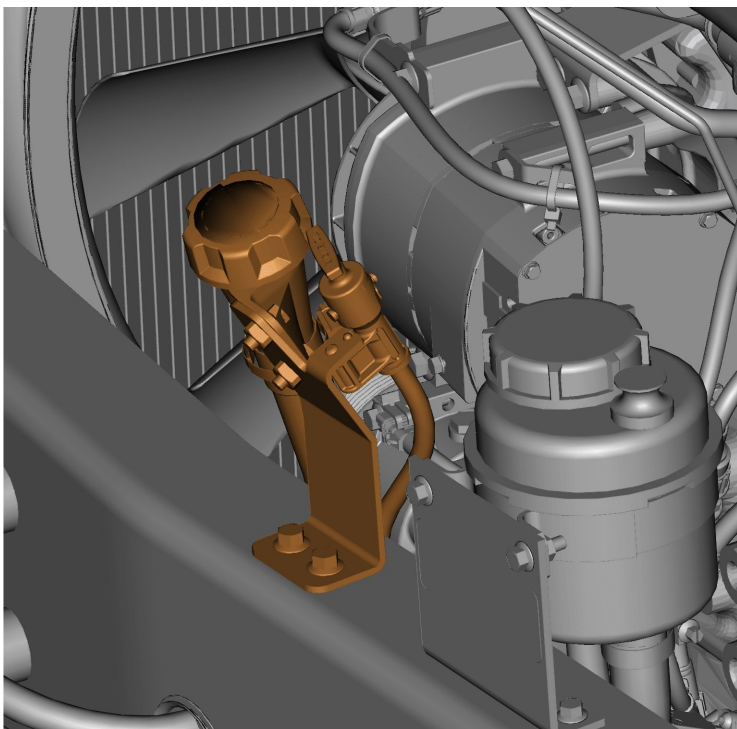

W2056443

# 82 Operator's Manual Vehicle Maintenance CXU, CHU, GU, TD, MRU and LEU

## Engine Air Filter

The air cleaner prevents dust, dirt and other harmful contaminants from entering the engine through the air intake system. Maximum engine protection can only be achieved through regularly scheduled maintenance practices that include periodic air intake system inspections and air filter element changes.

The most efficient method of determining air filter element change intervals is by regularly checking the air filter restriction gauge, which may either be mounted directly to the air cleaner canister, on the air cleaner outlet tube or inside the cab. The restriction gauge measures the amount of restriction in the air filter element. Some chassis may have a dash-mounted dial-type restriction gauge which measures filter restriction in mm/inches of water.

Change the air filter element in accordance with the procedures as outlined, when the restriction gauge red signal locks in full view, or the dash-mounted gauge indicates inlet restriction as follows:

### Mounted Gauge Inlet Restriction Indication

Engine	Millimeters (Inches) Water/kPa
MP7, MP8 and MP10	510 mm (20)/5 kPa

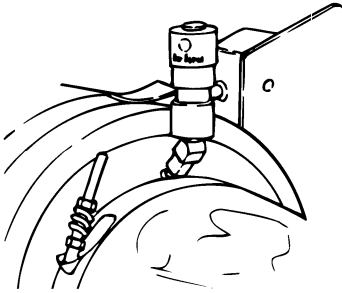

**FILTER MOUNTED GAUGE**

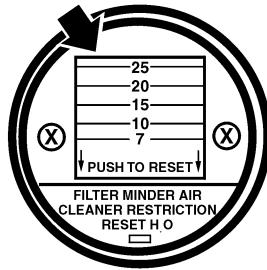

**DASH MOUNTED GAUGE** 201047a

W0054007

Air Filter Restriction Gauge

Damage to the air filter element, such as holes in the filter medium, will give an inaccurate restriction reading. Therefore, even if maximum restriction is not indicated, the air filter element should be changed yearly or at 160 000 Km (100,000 mile) intervals, whichever comes first.

When replacing the air filter element, or whenever the air inlet system has been disassembled, inspect the inlet air ducts between the air cleaner canister outlet and the turbocharger inlet as follows:

- Inspect the rubber elbows for cracks, splitting and/or holes. Rubber components must be flexible so that they conform to the plastic ducts and ensure a tight seal.
- Inspect plastic ducts for cracks and/or holes.
- Ensure that all hose clamps are properly installed and tightened to specifications.
- Make sure the plastic ducts do not rub against any components such as air conditioning hoses, wire harnesses, etc.

To properly install a new filter element:

- 1 Wipe the air cleaner housing clean.
- 2 Remove the filter element(s).
- 3 Inspect sealing areas for dirt tracks which would indicate that dust has leaked past the seal. If dirt tracks are found, the cause must be determined and corrected.
- 4 Thoroughly clean the inside of the air cleaner canister with a damp cloth or vacuum cleaner.
- 5 If equipped with a metal canister, inspect inside the canister for rust. If rust is present:
  - 1 Remove the air cleaner canister from the chassis.
  - 2 Remove all loose rust with a wire brush or a coarse Scotch Brite pad.
  - 3 Sand with 180/240 grit wet or dry sand paper.
  - 4 Thoroughly wash the area with PPG DX-440, DX-436, DX-437 or equivalent, wax and grease remover and wipe dry.
  - 5 Prime immediately with PPG DEP-351 epoxy primer.
  - 6 Reinstall the air cleaner canister.
- 6 Inspect the sealing areas of the housing for damage. Repair or replace as necessary.
- 7 Use MACK-approved replacement elements and gaskets. Make sure the new elements and gaskets are not damaged. Be sure to use new gaskets each time the element is changed. Install the cover and, depending upon cover configuration, tighten as follows:
  - Air cleaner with large wing nut in center of cover hand-tighten wing nut.
  - Air cleaner with three thumb screws around outer edge of cover hand-tighten thumb screws.
  - Air cleaner with retaining nuts around outer edge of cover tighten retaining nuts between 11 – 14 Nm (8 – 10 lb-ft).

# 84 Operator's Manual Vehicle Maintenance CXU, CHU, GU, TD, MRU and LEU

---

**Note:** DO NOT attempt to clean the air filter element with compressed air, as this could damage the filter medium and possibly result in severe engine damage.

## FOR BEST RESULTS...

### USE GENUINE



## REPLACEMENT PARTS AND FILTERS

000111a

W0053982

Replacement Parts and Filters



## **Exhaust After-Treatment System**

*CHU, CXU, GU and TD Standard System View*

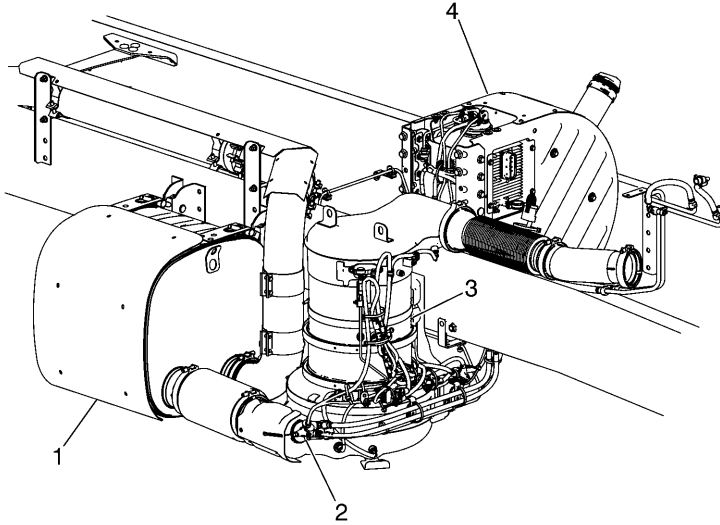

W2029933

1. Selective Catalytic Reduction (SCR) Catalyst
2. Aftertreatment DEF Dosing Unit
3. Aftertreatment Diesel Particulate Filter (DPF)
4. Aftertreatment DEF Tank

# 86 Operator's Manual Vehicle Maintenance CXU, CHU, GU, TD, MRU and LEU

## LEU and MRU Standard System View

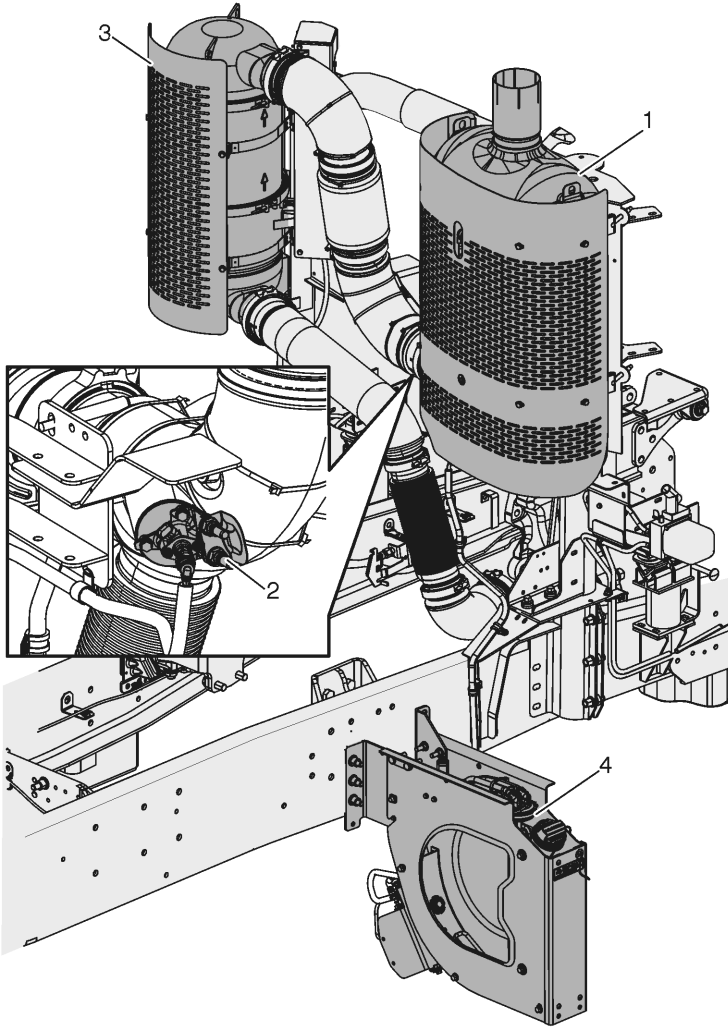

W2031562

1. Selective Catalytic Reduction (SCR) Catalyst
2. Aftertreatment DEF Dosing Unit
3. Aftertreatment Diesel Particulate Filter (DPF)
4. Aftertreatment DEF Tank



## DANGER

The SCR/DPF shield should not be removed while the vehicle is in use. Also, only remove the shield, once the vehicle is out of use and the SCR/DPF is sufficiently cooled. Failure to follow these instructions can result in fire, which can cause component damage, personal injury or death.



## CAUTION

The Diesel particulate filters and their components, **can not** be moved or altered from the OEM installation in any fashion. Any alterations may cause component damage and is prohibited by the law.

Check if the vehicle is equipped with a Diesel Particulate Filter (DPF) or a DPF and Selective Catalytic Reduction unit (SCR). These components are part of the overall vehicle emissions control system. In normal operation, these components can experience surface temperatures as high as 350° C (662° F). It is important to verify the temperature at which the material or substance in, or associated with, the body can ignite. If it is possible for the material or substance to fall or leak from the body, take steps to prevent them from contacting or collecting on the DPF or SCR. Failure to do so may result in fire.

It is important to note that additional shielding may, depending upon conditions and the material or substance, trap flammable substances between the additional shield and the DPF/SCR. If this condition can develop, advise the user of the vehicle to periodically check to ensure there are no trapped substances.

**Note: The DPF/SCR and associated components are part of a U.S. EPA and California Air Resources Board (CARB) certified engine emissions system. These components must not be moved, altered or modified in any way. Tampering with these systems render the emissions warranty void and may result in possible tampering charges by the EPA or CARB.**

# 88 Operator's Manual Vehicle Maintenance CXU, CHU, GU, TD, MRU and LEU

---

New stringent standards for exhaust emission control begin with the 2010 model year. The Diesel Particulate Filter (DPF) system has been developed to act in combination with Ultra Low Sulphur Diesel (ULSD) fuel to reduce particulate emissions to meet the requirement. The Exhaust After-Treatment System (EATS) includes all the engine and exhaust emissions control components that are required to meet the stringent 2010 standard.

Particulate matter consists of soot and ash in the exhaust that engines with an EGR system alone, are not equipped to handle. The particulate matter is considered a contaminant that contains undesirable elements. The DPF system reduces the unwanted elements to a more acceptable level defined in the regulations. There are multiple methods of reducing these emissions. MACK has selected to use a Diesel Oxidation Catalyst (DOC) with a catalyzed diesel particulate filter. The other uses a diesel particulate filter of a different kind without a DOC and in its place uses a combustion chamber to heat the exhaust mixture thus causing active regeneration.

The particulate matter removed from the exhaust collects on the filter surfaces. To avoid eventual blockage, which would increase exhaust back pressure and affect power and fuel economy, the filter must be cleaned. The DPF is cleaned automatically. The soot breaks down to safer substances before being released to the atmosphere. Some of the ash remains, but takes a long time to reach the point where ash clogs the filter.

Cleaning a filter so it can continue to function is called "regeneration." Either system uses high heat to break down the chemical properties. Depending on vehicle usage, the engine is equipped with a passive or active regeneration system.

In "passive regeneration," the exhaust produces enough heat continuously to convert the soot, with approximately 260 °C (500 °F) being required. The process is slow and continues indefinitely. Passive regeneration is possible only in vehicle applications where the temperature is likely to remain at or above the required temperature level, making active regeneration unnecessary.

During an active regeneration, the temperature of the filter must be raised to 500 °C (932 °F). To produce this temperature, the system uses a hydrocarbon injector or Aftertreatment Fuel (AF) injector to introduce fuel into the exhaust stream as it leaves the turbocharger. The hot exhaust ignites the fuel which produces the regeneration temperature. When the DPF becomes restricted to a minimum volume, the engine ECU starts the fuel injection into the exhaust. When the air flow rate returns to normal through the DPF, the engine ECU turns the injector off.



## **WARNING**

Prior to ever working on the exhaust, allow time for the entire exhaust system to cool. Failure to do so may result in personal injury. Severe burns can occur.

## Selective Catalytic Reduction (SCR)

Selective Catalytic Reduction (SCR) is an emissions-reduction technology with the ability to deliver near-zero emissions of nitrogen oxides (NOx), a smog-causing pollutant and greenhouse gas. SCR's performance has been proved in millions of miles of real-world truck operations in other countries, as well as in long-term field tests in the U.S.

SCR reduces NOx emissions to very low levels, while at the same time delivering excellent fuel economy and reliability. The system doesn't change the design or operation of the basic engine. Rather, SCR is an aftertreatment system which converts NOx in the exhaust stream into harmless gases. Modern diesels already use exhaust aftertreatment systems, called diesel particulate filters, to control emissions of another pollutant, soot (also known as particulate matter or PM).

SCR works by injecting Diesel Exhaust Fluid (DEF) into the exhaust stream, after the DPF. DEF is a safe, simple solution of water and urea. DEF works with the heat of the exhaust and a catalyst to convert NOx into nitrogen and water vapor - two harmless and natural components of the air we breathe. The end result is cleaner air, excellent fuel efficiency and a reliable emissions control system for today's modern diesel engine.

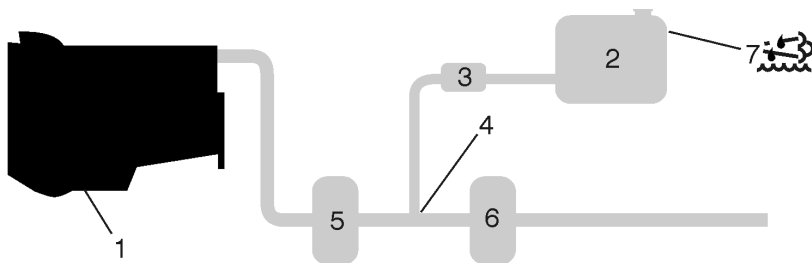

W2031651

1. Diesel Engine
2. Aftertreatment DEF Tank
3. Aftertreatment DEF Pump
4. Aftertreatment DEF Dosing Unit
5. Aftertreatment Diesel Particulate Filter (DPF)
6. Selective Catalytic Reduction (SCR) Catalyst
7. Aftertreatment DEF Tank Gauge

## 90 Operator's Manual Vehicle Maintenance CXU, CHU, GU, TD, MRU and LEU

---



### CAUTION

Do not put diesel fuel in the Aftertreatment DEF tank. Diesel fuel, if sprayed into the hot exhaust along with the DEF, could ignite explosively causing a fire resulting in personal injury or damage to the exhaust system.

There are two different configurations for the SCR catalysts, they are vertical and horizontal. The horizontal SCR catalyst comes in two different sizes, one for the MP7/MP8 engines and larger size for the MP10 engine. The vertical SCR catalyst also comes in two different sizes, one for the MP7/MP8 engines and larger size for the MP10 engine.

The MACK SCR system is simple and effective, with few components. It consists of a Aftertreatment DEF tank positioned near the standard diesel tank, plus a Aftertreatment DEF pump, Aftertreatment DEF Dosing unit and SCR catalyst. The advantage of using DEF is that it enables the engine to use less EGR -- and higher oxygen levels -- for better combustion, while meeting the EPA near-zero NO<sub>x</sub> emissions requirement of 0.2 g/hp-hr NO<sub>x</sub>. By using DEF, we avoid the disadvantages of increasing EGR to massive levels. This results in better fuel economy from your MACK engine.

## **Diesel Exhaust Fluid (DEF)**

Diesel Exhaust Fluid (DEF) is a reactant that's key to the SCR process. It's a nontoxic, aqueous solution of urea and water. Urea is a compound of nitrogen that turns to ammonia when heated. It is used in a variety of industries, perhaps most commonly as a fertilizer in agriculture. The fluid is not flammable, nor is it dangerous when handled normally. However, it is highly corrosive to metal, particularly copper and aluminium. Read the separate section concerning the handling of DEF solution. Only use approved DEF fluid.



# 92 Operator's Manual Vehicle Maintenance CXU, CHU, GU, TD, MRU and LEU

## Diesel Exhaust Fluid (DEF) Handling

When handling DEF solution, it is important that electrical connectors to be connected or well encapsulated. Otherwise there is a risk that the DEF will cause oxidation that cannot be removed. Water or compressed air do not help, since DEF quickly oxidizes metal. If a connector comes into contact with the DEF solution it must be replaced immediately to prevent the DEF solution from creeping further into the copper wiring, which takes place at a speed of about 60 cm (2.4 in) per hour.



### CAUTION

When detaching hoses and components, do not spill DEF on disconnected connectors. If DEF is spilled on a connector, the connector must be replaced immediately

### Things to know about spilled Diesel Exhaust Fluid (DEF)

If urea solution comes into contact with the skin, rinse with plenty of water and remove contaminated clothing.

If urea solution comes into contact with the eyes rinse for several minutes and call for medical help if necessary.

If inhaled breathe fresh air and call for medical help if necessary.

Do not allow the DEF solution to come into contact with other chemicals.

The DEF solution is not flammable. If the DEF solution is exposed to high temperatures, it breaks down into ammonia and carbon dioxide.

The DEF solution is highly corrosive to certain metals, including copper and aluminium.

If the DEF solution is spilled onto the vehicle, wipe off the excess and rinse with water. Spilled DEF solution can form concentrated white crystals on the vehicle. Rinse off these crystals with water.

**Note:** Do not flush DEF spills into the normal drain system.



### WARNING

DEF spilt onto hot components will quickly vaporize. Turn your face away!



## *Diesel Exhaust Fluid (DEF) Consumption*

DEF consumption is related to fuel consumption. A highway truck may travel 225-300 miles or more on one gallon of DEF. A gauge much like a fuel gauge will indicate the level of DEF in the tank. A DEF low-level warning will activate when DEF is low. If a driver runs out of DEF completely, vehicle power will be reduced to derate mode. When the DEF tank is refilled, the engine will resume normal power.

**Note:** DEF tanks are sized for a two to one fuel to DEF ratio in order to meet EPA 2010 requirements.

## *Diesel Exhaust Fluid (DEF) Availability*

DEF will be available in 2.5 gallon containers, 55 gallon drums, 275 gallon IBC and in bulk storage for fleet locations, truck stops and dealerships. All major truck stops, dealers and distributors will carry DEF. For more information on DEF and availability please visit the website [www.Mackscr.com](http://www.Mackscr.com).

## Drive Belt Replacement Intervals

If belts squeak or squeal, clean with hydraulic brake fluid or an approved cleaning fluid. Replace belts that are severely worn or frayed.

### Rib Cracking

An in-service poly V-belt will go through several phases of cracking during its life. After an extended time in service, minor rib cracks may appear, usually one or two cracks per inch. This cracking is normal.

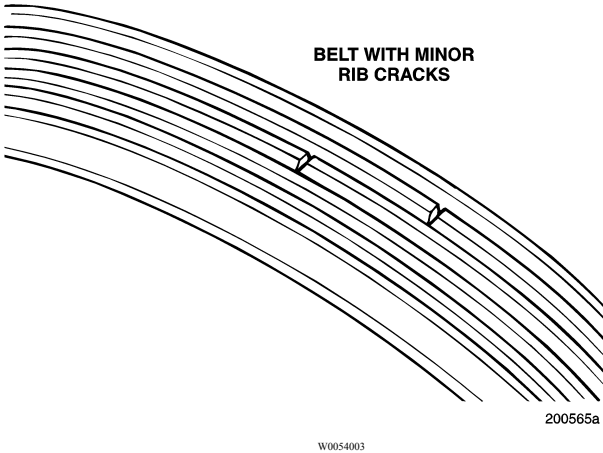

Belt with Minor Rib Cracks

# Operator's Manual Vehicle Maintenance CXU, CHU, GU, TD, MRU and LEU 95

---

Belts should not be replaced unless the ribs exhibit severe multiple cracking as shown below. Multiple cracking will lead to rib chunking.

**BELT WITH MULTIPLE  
CRACKING**

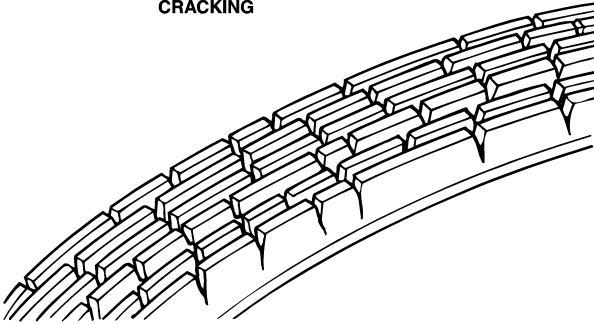

200566a

W0054004

Belt with Multiple Cracking

**BELT WITH  
SEVERE CRACKING AND  
RIB CHUNKING**

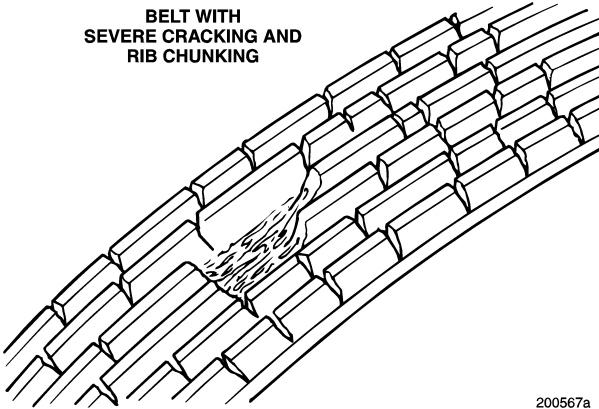

200567a

W0054005

Belt with Severe Cracking and Rib  
Chunking

# 96 Operator's Manual Vehicle Maintenance CXU, CHU, GU, TD, MRU and LEU

---

## Rib Sidewall Glazing

When the belt ribs appear to have a shiny surface that is hard and brittle, it is usually an indication of belt slippage. This is attributed to inadequate tension and/or extreme temperature. Both these conditions will lead to severe cracking and belt failure, often with little advance warning. If this occurs, locate the cause and correct before installing a new belt.

## Belt Wear

Accelerated wear on any part of the belt (fabric backing, tensile cord or rib rubber) is a concern and should be investigated for cause, and corrected before installing a new belt.

## Possible Causes of Accelerated Belt Wear

- Drive Misalignment Belt performance will be adversely affected when misalignment exceeds 1/16 inch for every 12 inches of belt span.
- Belt Length Must be correct.
- Environmental Conditions Temperature, exposure to engine fluids, etc.
- Abrasive Materials Small stones, metal shavings, etc.

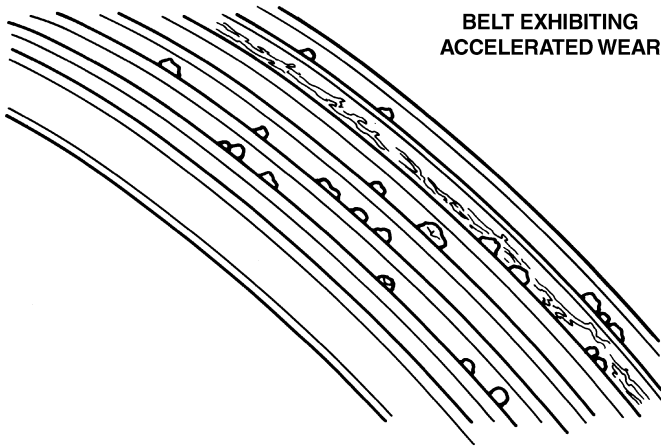

**BELT EXHIBITING  
ACCELERATED WEAR**

## Foreign Objects

Any object protruding in the path of the belt drive and contacting the belt will cause damage and eventual failure. Locate the object before installing a new belt. (See )

**DAMAGE FROM OBJECT  
PROTRUDING IN BELT PATH**

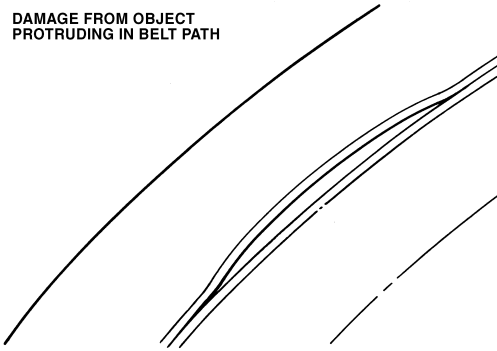

205270a

W0054011

Damage from Object Protruding in Belt  
Path

## Noise, Vibration and Harshness (NVH)

Poly V-belt drive systems were designed to prevent Noise, Vibration and Harshness (NVH) problems. Field problems, however, which may be related to NVH causes occasionally occur.

# 98 Operator's Manual Vehicle Maintenance CXU, CHU, GU, TD, MRU and LEU

---

## Possible Causes

Insufficient belt tension may create a high-pitched howl (squeal) or rasping sound during engine acceleration or deceleration.

Misalignment may cause a chirping noise, especially at, or near, idle speed. Rigid bracketing of accessories is a must for reasonably vibration-free belt spans. Some span vibration is to be expected during the range of engine speed and accessory loading.



### **WARNING**

Failure to follow recommended application information and recommended procedures for installation, care maintenance and storage of belts may result in failure to perform properly and may result in damage to property and serious bodily injury. Make sure the belt selected for any application is recommended for that service.

## Drive Belt Installation

To install a poly V-belt, swing the automatic tensioner to the full sprung position (fully toward the install stop), then place the belt over the pulleys. Slowly return the automatic tensioner back to its original position. Do not allow the tensioner to snap against the stops. For proper belt routing, refer to the following belt routing diagrams. Before installing the new belt, ensure that the pulley grooves are clean and free of debris.

Certain GU and CXU model chassis equipped MP7 engines utilize a 10-rib belt on 12-rib pulleys. When replacing the belt, the belt must be installed against the rear face of the pulley (edge of pulley closest to the engine) as shown in the illustration below.

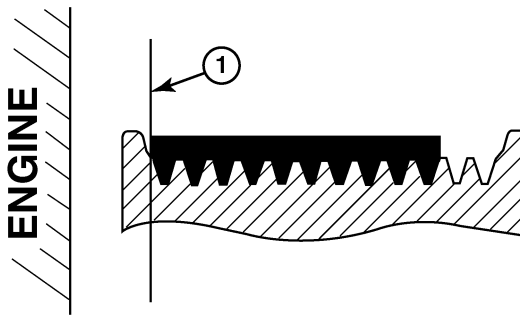

271579a

W0054031

10-Rib Belt Installation on 12-Rib Pulley

1. Install 10-rib belt against rear edge of 12-rib pulley.

Drive Belt Routing MACK MP7 and MP8 engines, all models.

# 100 Operator's Manual Vehicle Maintenance CXU, CHU, GU, TD, MRU and LEU

---

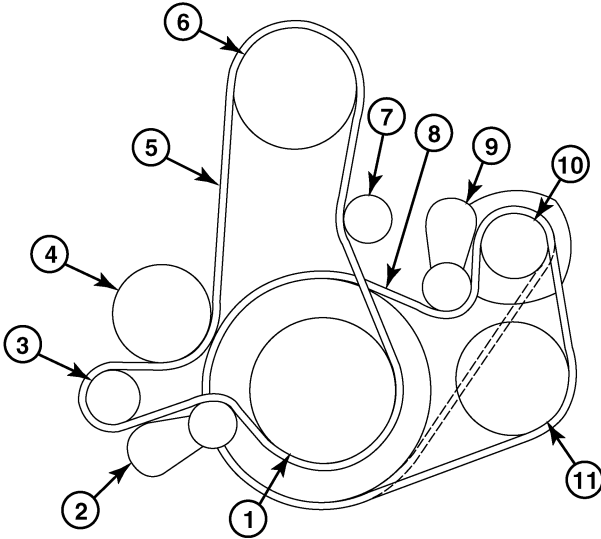

270176a

W0054017

Drive Belt Routing MP7 and MP8 Engines

1. Crankshaft Pulley	7. Idler Pulley (when applicable)
2. Automatic Tensioner	8. Accessory Drive Belt
3. Idler Pulley	9. Automatic Tensioner
4. Water Pump	10. Alternator
5. Main Drive Belt	11. Air Conditioner Compressor (if equipped)
6. Fan Drive	

Drive Belt Routing MACK MP7 and MP8 engines, all models.



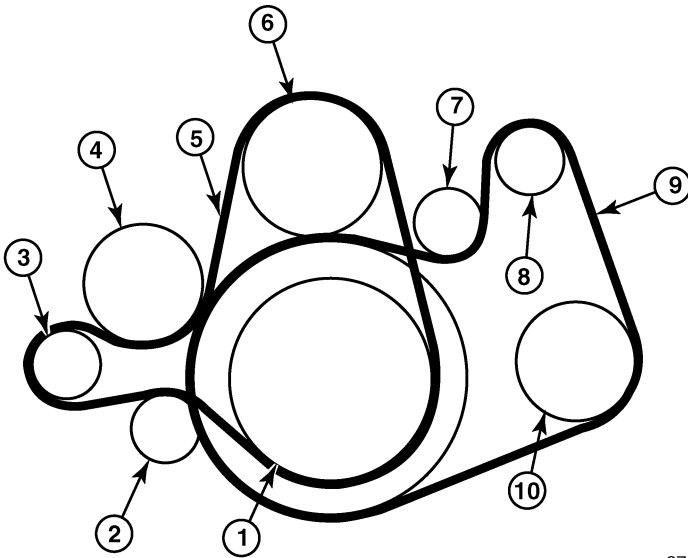

273221a

W0054041

Drive Belt Routing MP10 Engine

1. Crankshaft Pulley	6. Fan Drive
2. Idler Pulley	7. Automatic Tensioner
3. Automatic Tensioner	8. Alternator
4. Water Pump	9. Accessory Drive Belt
5. Main Drive Belt	10. Air Conditioner Compressor

# 102 Operator's Manual Vehicle Maintenance CXU, CHU, GU, TD, MRU and LEU

## Automatic Belt Tensioner Maintenance

The automatic belt tensioner is designed to maintain proper belt tension throughout the life of the tensioner. The belt tensioner cannot be adjusted or repaired. At each D inspection interval or once per year, whichever occurs first, check the following:

- With the belt on the drive, check the following:

Check to see if the tensioner is resting against the install stop or the free-arm stop. If the tensioner is resting against either stop, the tensioner must be replaced.

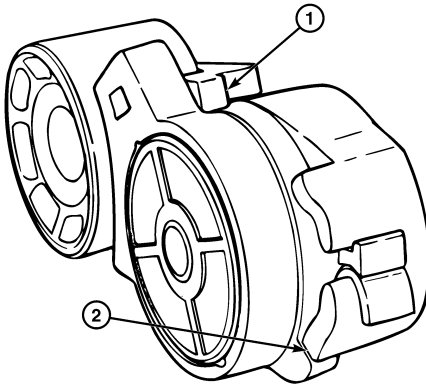

267588a

W0054013

Tensioner Install Stop and Free-Arm Stop (Main Drive Belt Tensioner Shown)

1. Install Stop

2. Free-Arm Stop

On main drive belt tensioners, check belt tracking. If the belt is tracking all the way to one side of the tensioner pulley (either the front- or back-side), replace the tensioner. Belt tracking can be determined by looking at the witness mark (the shiny area on the pulley where the belt rides). The witness mark should be approximately the same width of the belt.

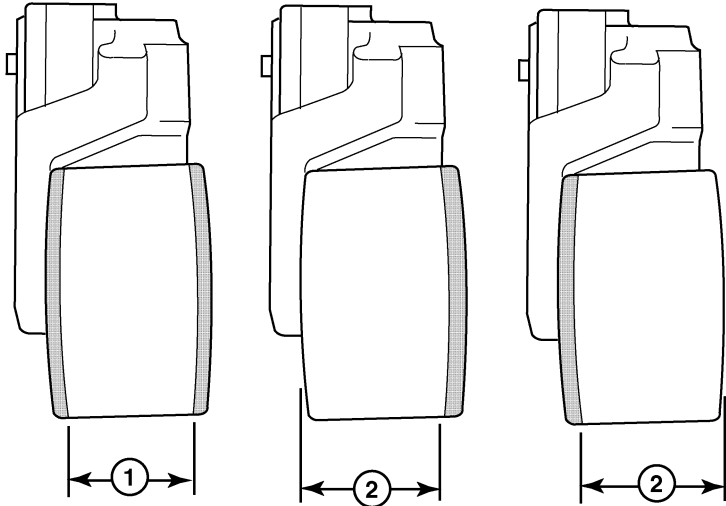

267589b

W0054014

Main Drive Belt Tensioner Belt Tracking Witness Mark

- |  |   |
|--|---|
| 1. Acceptable (Witness Mark<br>Approximately Same Width as Belt) | 2. Not Acceptable (Witness Mark<br>Tracking Off Edge of Pulley) |
|--|---|

- Remove the belt by using a 3/8 inch breaker bar to pull the tensioner back to the install stop. Slowly return the tensioner to the free-arm stop.
- With the belt removed, use the breaker bar to slowly pull the tensioner from the free-arm stop to the install stop and then slowly releasing it back to the free-arm stop. Any excessive roughness or hesitancy noticed while performing this check indicates that the tensioner must be replaced.
- Check for metal-to-metal contact as follows:  
Check for contact between the arm and the spring case. Replace if metal-to-metal contact is seen.

# 104 Operator's Manual Vehicle Maintenance CXU, CHU, GU, TD, MRU and LEU

---

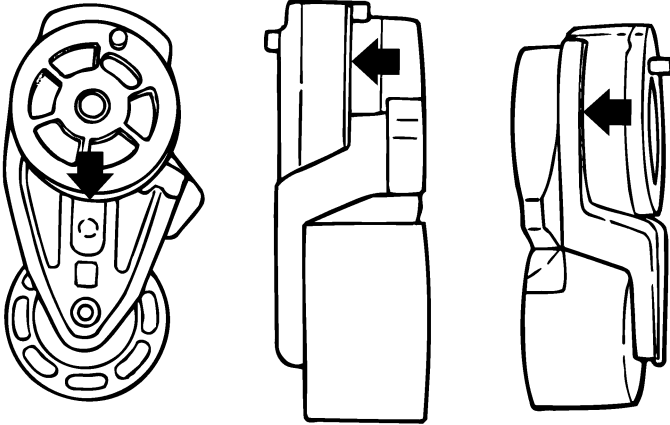

267590a

W0054015

Checking for Contact Between Arm and Spring Case

Check for metal-to-metal contact between the arm and the end cap. Replace if contact is seen.

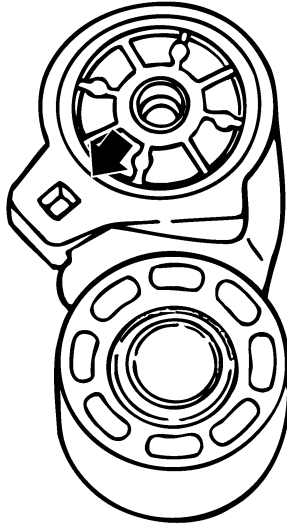

267591a

W0054016

### Checking for Contact Between Arm and End Cap

Check for cracks in the tensioner body or for broken stops on the spring case. If either is seen, replace the tensioner.

Reinstall the belt making sure that the belt is properly seated in the grooves of ALL pulleys.



### CAUTION

If an automatic belt tensioner must be replaced, make sure that the proper tensioner is used. Tensioner spring tension varies by engine and chassis model. Do not substitute one tensioner part number for another, as drive belt failure can result.

## Turbocharger and Charge Air Cooler

### **DANGER**

If oil leaks internally from the turbocharger to the engine intake, the oil acts as a fuel. Watch for excessive exhaust smoke. **DO NOT** operate engine until problem is corrected. There is no way to regulate the engine speed if it runs on oil and it may over speed. Loss of control of vehicle may lead to an accident causing severe personal injury or death.

### **WARNING**

**DO NOT** remove, attach, or tighten turbocharger air intake ducting while the engine is operating, or operate the engine while the ducting is removed. Working around the turbocharger with the ducting removed may cause severe personal injury.

Visually inspect turbo mountings, intake and exhaust ducting and connections for leaks on a daily basis. Check oil inlet and outlet for leaks or signs of restrictions to oil flow. Check for unusual noise or vibration. If any faults are detected, do not operate the engine until the cause is determined and repaired.

## **Cleaning Charge Air Cooler and Radiator Package**



### **WARNING**

Always wear eye protection when cleaning radiator, charge-air cooler and condenser. Failure to follow this recommendation may result in eye injury.



### **CAUTION**

When using a pressure washer to clean the vehicle, do not direct the spray at electrical components in the engine compartment such as the alternator, starter and compressors. Water spray from pressure washers can damage electrical components.

Periodically inspect the front of the radiator/charge-air-cooler package for buildup of dirt, mud, insects, etc. Over time, there may be a build-up of dirt, mud, insects, etc., between the radiator and charge air cooler. Inspect for build-up and contact your authorized MACK Truck dealer, if necessary.

Over time, dirt and insects will accumulate between the fins of the radiator, air conditioning condenser and charge-air-cooler. The reduced air flow reduces the heat transfer from the components to the air. This increases the load on the fan and air conditioning compressor and can result in engine overheating and other performance related problems, such as high fuel consumption, etc.

# 108 Operator's Manual Vehicle Maintenance CXU, CHU, GU, TD, MRU and LEU

---

The simplest method to clean the package is to use air pressure or a water stream. This should be done from the back of the core. Air pressure should not exceed 30 psi (200 kPa) for radiator and charge air cooler cores. The use of a fin comb is also a good tool to loosen bugs and dirt from the fins. If dirt cannot be cleaned off with this procedure, consult your MACK Truck dealer.

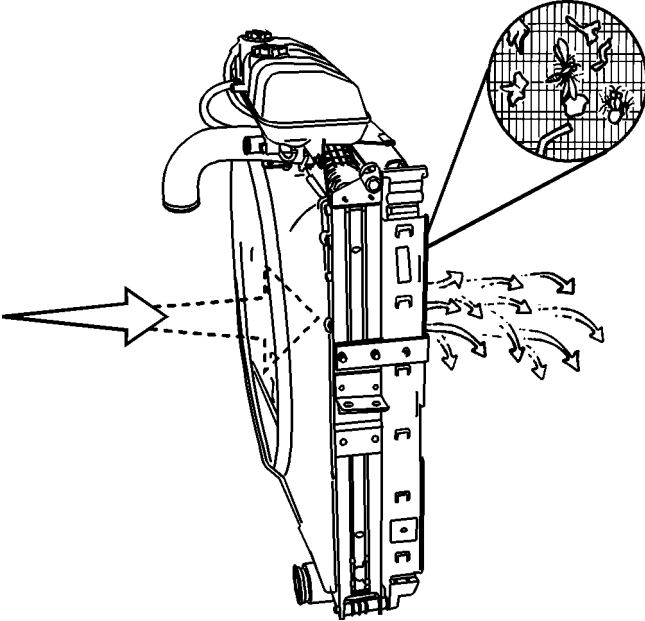

W2001496

Cleaning Charge Air Cooler and Radiator  
(typical radiator shown)

Inspect the charge air cooler for cracks at every inspection. **DO NOT** operate the vehicle with a damaged or broken charge air cooler. To do so would void the warranty and the engine will not meet emission regulation requirements.



## Preventive Maintenance Air Suspensions

**Note:** The following maintenance items should be performed on all air suspensions (including MACK AL, AL II, AL-401LH, MAXAIR 40/40A, MAXLITE 2040, MAXLITE 2040 EZ and Hendrickson PRIMAAX) at each B, C and D inspection interval, or every 40 234 Km (25,000 miles) or six months, whichever comes first.

- **Visual Inspection:** Inspect all suspension components, checking for signs of wear, damage or unwanted movement. Look for bent or cracked parts. Replace all worn or damaged components as required.
- **Air Spring:** Inspect for chafing or any signs of spring or components damage. Ensure that the upper bead plate is tight against the underside of the frame. Check for lateral slippage at the lower air spring bracket. Slippage of 3.3 mm (1/8 inch) in either direction is acceptable. Replace worn or damaged components as required.
- **Support Beam Assembly:** Inspect the overall condition of the support beam for dents, dings or other damage. On Hendrickson PRIMAAX suspensions, check the D-pin bushings for tearing or extreme bulging. Check for metal-to-metal contact in the bushed joints. Replace worn or damaged components as required.
- **Frame Hanger Bracket:** Inspect for any signs of loosening or damage. On Hendrickson PRIMAAX suspension, check for loosening or damage at the QUIK-ALIGN connections or longitudinal torque rod connections. Replace worn or damaged components as required.
- **Cross Beam:** Inspect for cracks, damage, metal shavings or looseness at the beam connections. Replace worn or damaged components as required.
- **Transverse Torque Rods:** Inspect for signs of looseness at the transverse torque rod connections. Check bushings for tearing or excessive bulging. Check the transverse torque rod for dents or bending. Replace worn or damaged components as required.
- **Shock Absorbers:** Inspect for signs of dents or leaking (oil misting is not considered leakage). Replace worn or damaged shocks as required.
- **Tire Wear:** Inspect tires for wear patterns that might indicate suspension damage or misalignment. Replace worn or damaged components as required.
- **Height Control Valve and Air Lines:** Check for loose, bent or damaged parts. Check air lines for chafing or any unwanted contact with moving components. Check height control valve and air lines for leakage. Replace worn or damaged components as required.

## Steering and Brakes Maintenance

### Steering System

Excessive play in the steering system is checked by turning the steering wheel while the engine is stopped. With the front wheels pointing straight ahead, turn the steering wheel until the front wheel starts moving. Then, turn the steering wheel the other way until the front wheel moves. Play should not be more than 25 mm (1 in) at the rim of the steering wheel. If the steering play is excessive, check the steering linkage for looseness, wear, etc. Make necessary repairs before driving the vehicle.

### *Power Steering Fluid Reservoir*

The power steering fluid reservoir is filled with Automatic Transmission Fluid (ATF) Dexron III for the power steering system. If the fluid has darkened, it indicates that the power steering system is running hotter than normal and the fluid is overheating. Take the vehicle to a MACK Truck dealer for troubleshooting the overheating and to have the fluid changed.

## Brake System



### DANGER

DO NOT use replacement parts anywhere in the brake system unless it conforms exactly to original specifications. A nonconforming part in your vehicles brake system could cause a malfunction, leading to loss of control of the vehicle resulting in severe personal injury or death.



### DANGER

DO NOT release the parking brake or attempt to move the vehicle until brake air pressure in both circuits is at least 100 psi (690 kPa). Failure to follow this procedure may lead to uncontrolled vehicle movement and cause severe personal injury or death.



### DANGER

Automatic slack adjusters MUST NOT be manually adjusted in an effort to correct excessive push rod stroke, as this condition indicates that a problem exists with the automatic adjuster, installation of the automatic slack adjuster or problems related to components of the foundation brakes. These conditions will not be corrected by manually adjusting the automatic slack adjusters.

Manual adjustment of automatic slack adjusters is a dangerous practice that could result in serious consequences. This practice gives the vehicle operator a false sense of security about the effectiveness of the brakes, and the brakes will likely soon be out of adjustment again.

**Note:** The brake system is a critical vehicle safety system. For your safety and for those around you, follow the recommended preventive maintenance checks. If any problems occur, have them investigated immediately by an authorized service facility.

The following Dual Circuit Brake System Function Test should be performed at each C and D inspection interval, or after any air system service procedures that involve disconnecting and reconnecting air lines where incorrect reconnection, such as the treadle valve, is a possibility.

- 1 Block the wheels to prevent the vehicle from moving.
- 2 Start the engine and build air system pressure to governor cutout.
- 3 Stop the engine.
- 4 Completely drain one air reservoir.
- 5 Release the parking brakes.
- 6 Apply and hold the treadle valve.

# 112 Operator's Manual Vehicle Maintenance CXU, CHU, GU, TD, MRU and LEU

---

- 7 Have an assistant check for proper results by observing the movement of the slack adjusters as indicated below:

TRUCK:

- The brakes on the rear drive axle(s) should always apply as indicated by movement of the slack adjuster.
- The low-air warning buzzer and warning lamp should activate for at least two of the tests.

TRACTOR:

- The brakes on either the steering axle or the rear drive axle(s) should always apply as indicated by movement of the slack adjuster.
- The low-air warning buzzer and warning lamp should activate for at least two of the tests.

- 8 Repeat the above procedures for the remaining air reservoirs (do not include air reservoirs for air starter if so equipped).

## *Air Tanks*



### **DANGER**

Drain the air system tanks at the recommended intervals. If condensation accumulates, moisture can enter the brake system air valves, causing corrosion or clogging. The safety of the brake system could be compromised, leading to an accident causing severe personal injury or death.



### **WARNING**

When draining the air tanks, **DO NOT** look into the area of the draining air. Dirt or sludge particles may be in the air stream that could cause eye injury.

Air tanks should be drained daily. Make sure the drain cocks close properly after draining. Empty moisture from air tanks by pulling the drain valve lanyard or pull cord. The tanks should be checked for condensation fluid, even if an automatic drain valve is installed.

It is very important that the air system is kept clean. If sludge or oil is found in the drainage or an excessive amount of fluid is drained out of the tanks see your authorized MACK Truck dealer.

## *Air Dryers*

Effective mid-September 2008, all MACK chassis are equipped with air dryers which utilize an oil coalescing desiccant cartridge which removes atomized oil and other particulate matter from the air system. The oil coalescing desiccant cartridge must be changed yearly. Refer to the specific air dryer service literature for detailed information.

# 114 Operator's Manual Vehicle Maintenance CXU, CHU, GU, TD, MRU and LEU

---

## Tires, Wheels and Hub Maintenance

### Wheel Safety Information



#### **DANGER**

DO NOT attempt to repair wheels or tires unless you are trained and equipped to do so. Wheel and tire assemblies cannot be worked on without proper tools and equipment. Failure to follow this may lead to serious personal injury or death.



#### **DANGER**

Failure to properly torque-tighten the wheel nuts can result in the breakage of wheel studs and the subsequent loss of wheels. Loss of vehicle control and serious personal injury or death can occur.



#### **DANGER**

DO NOT use oil or grease on studs or nuts. The tightening torque is affected and can lead to incorrect clamping loads between the rim and hub. This could lead to a loss of the wheel. Loss of vehicle control and serious personal injury or death can occur.



#### **DANGER**

DO NOT install regrooved, retreaded or repaired tires on the steering axle(s). They could fail unexpectedly and cause the loss of vehicle control, leading to serious personal injury or death.



#### **DANGER**

DO NOT use mismatched wheel components. If they do not exactly match the original design specifications, they may cause failure or separation leading to blowout and an accident and personal injury or death.



**DANGER**

DO NOT install tires with a load rating that is less than stated on the Certification Label in the door frame. The tire could be unintentionally overloaded, leading to an accident, causing serious personal injury or death.



**DANGER**

DO NOT use mismatched tires on the same axle. Always use the same type (radial or bias ply) or size. Mixing tires on the same axle will affect the roadholding and can lead to an accident, and serious personal injury or death.

## Wheels



**DANGER**

Before checking the wheels, set the parking brakes, place the transmission in neutral and chock the wheels. Failure to do so can result in unexpected vehicle movement and can cause serious personal injury or death.



**DANGER**

Wheels must be serviced only by a qualified technician. DO NOT do this work yourself. Inflated tires on wheels contain compressed air and if suddenly released, do so with an explosive force, resulting in serious personal injury or death.

Check wheels for signs of rust streaks around the wheel nuts. This indicates looseness (steel rims). Inspect all types of rims for cracks. Cracks can appear in many places but typically radiate out from where a load is applied. Inspect closely around wheelnuts, handholes and inside circumference.

## Wheel Nut Tightening



### DANGER

Failure to properly torque-tighten the wheel nuts can result in the breakage of wheel studs and the subsequent loss of wheels. This can lead to loss of vehicle control and serious personal injury or death.

After the initial tightening, retightening must be made within the first 800 Km (500 miles). After the first retightening, only normal inspection of nut tightness is needed. Check front and rear wheel nut tightness with a torque wrench. All disc wheels for MACK vehicles have a tightening torque of 610 Nm (450 lb-ft). Tighten the nuts in the correct sequence. Inspect bolts and nuts for signs of wear or cracks. Make sure that the bolts are not bent. This tightening check is particularly important when rims or brake drums are newly painted. Paint can flake off from these surfaces, causing the nuts to lose their grip and the wheel to loosen.

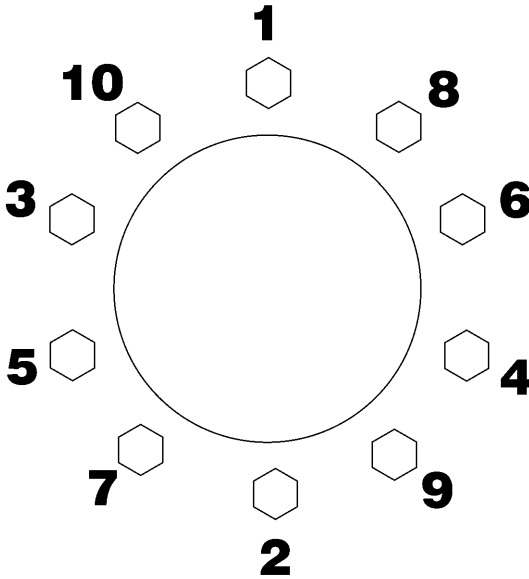

W7001392

10-Stud Wheel Nut Tightening Sequence









































































































