

RWRG0078 - Fault Code 63 Pre-Authorization

Overview

The UltraShift *PLUS* transmission is equipped with an X-Y Shifter that selects a transmission gear. The X-Y Shifter motors are controlled with electrical current supplied by the TECU to move the Shift Finger either side-to-side (rail selection) or fore-and-aft (gear engagement and disengagement). Fault Code 63 indicates a failure of the circuit controlling the Gear Motor and the fore-and-aft movement of the X-Y Shift Finger.

Note: it has been determined that performing an electrical pre-test is not needed.

Symptom(s)

- “F” flashes in gear display.
- Service light flashes (if equipped).
- Engine may not crank.
- Transmission may not engage a gear from neutral.
- Transmission does not shift while the vehicle is moving.
- Until the fault becomes Inactive, driver may have to shut off engine with transmission in gear.

Warranty Coverage

This Warranty Repair Guideline repair DOES NOT apply if the Fault Code is Inactive and there are other Active Faults in the Eaton/OEM System. If there are other Active Faults, please follow normal troubleshooting procedure using the correct troubleshooting manual per transmission model.

This Pre-Authorization DOES NOT apply if the failed part has been replaced within the last 90 days on the truck.

This Pre-Authorization DOES NOT apply if the failed component is mounted to a Medium Duty transmission.

The warranty coverage varies depending on vehicle vocation and transmission model type. Warranty coverage is the same as that of its respective transmission coverage including extended warranty.

Possible Causes

FMI 1, 5

- Transmission Harness
- X-Y Shifter Gear Motor

Component Identification

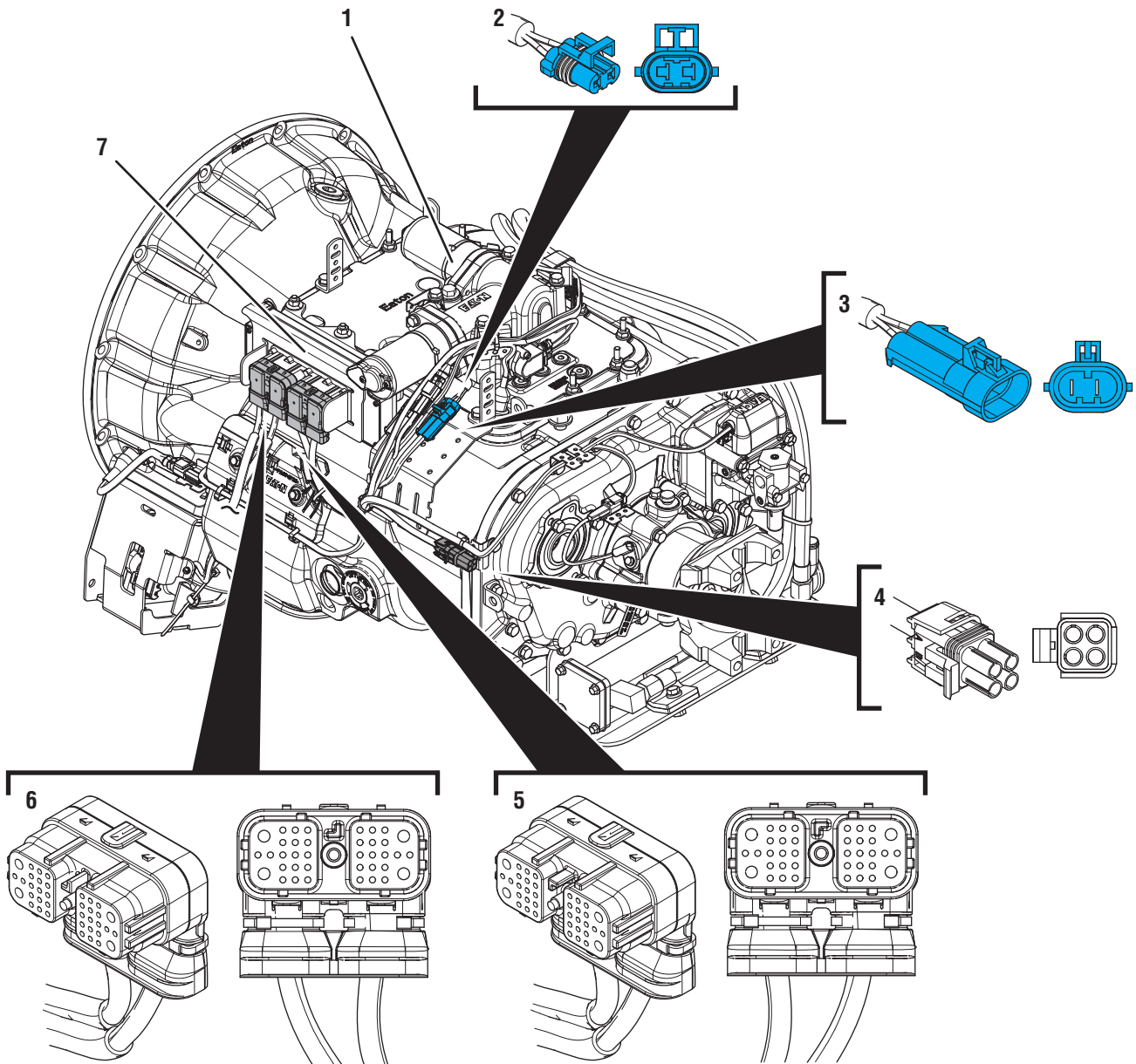

- 1. X-Y Shifter
- 2. 2-Way Gear Motor Connector (blue)
- 3. 2-Way Gear Motor Connector Body (blue)
- 4. 4-Way Diagnostic Connector
- 5. 38-Way Transmission Harness Connector
- 6. 38-Way Vehicle Harness Connector
- 7. Transmission Electronic Control Unit (TECU)

Pre-Authorized Warranty Repair Guideline RWRG0078

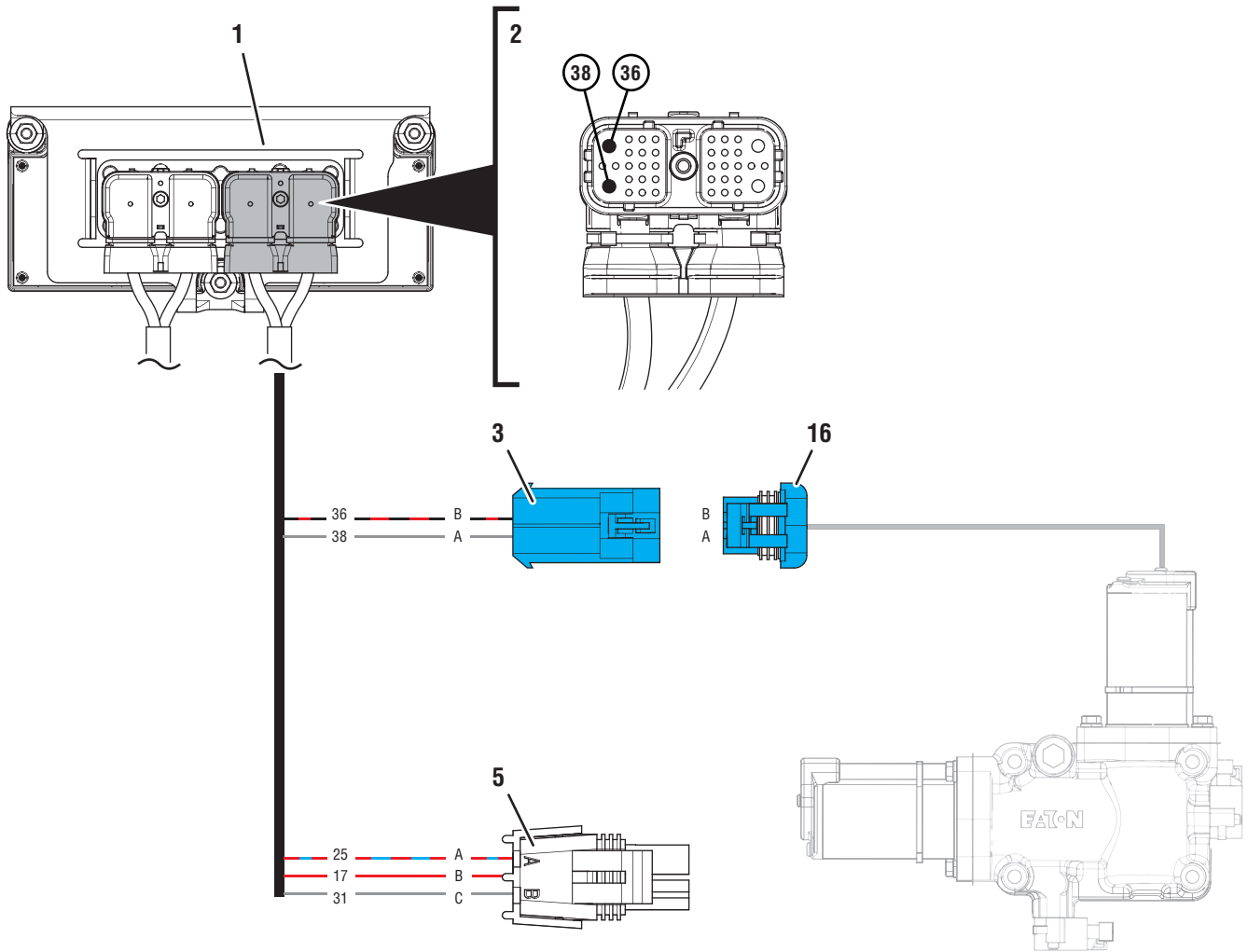

- 1. Transmission Electronic Control Unit (TECU)
- 2. 38-Way Transmission Harness Connector
- 3. 2-Way Gear Motor Connector Body (blue)
- 4. 2-Way Gear Motor Connector (blue)
- 5. 4-Way Diagnostic Connector

■ Battery Voltage	■ Switched Battery from TECU	■ Ground	■ Communication	■ Signal
■ Ignition Voltage	■ Switched 5V from TECU	■ Switched Ground	■ Relay/Solenoid Driver	

Fault Code 63 Troubleshooting

A *Purpose: Check for Active or Inactive fault codes.*

1. Record the transmission fault codes, FMIs, occurrences, and timestamps from the Service Activity Report created during the Diagnostic Procedure. Determine Fault Code 63 FMI 1 or 5.
 - If Fault Code 63 FMI 1 is active or inactive, go to **Step B.**
 - If Fault Code 63 FMI 5 is active or inactive, remove X-Y Shifter and inspect for coolant contamination. If contamination is found, service per RWRG0005.
 - if no contamination, replace X-Y shifter and Transmission Harness, go to **Step V.**

B *Purpose: Verify if FMI 1 is set Active/Inactive.*

1. Determine Fault Code FMIs.
 - If FMI 1 is inactive. Replace X-Y Shifter. If it is Key on Active, proceed with Normal troubleshooting methods found in appropriate manual. Go to **Step V.**
-

V *Purpose: Verify repair.*

1. Key off.
2. Reconnect all connectors and verify that all components are properly installed.
3. Key on with engine off.
4. Clear fault codes using ServiceRanger.
5. Drive vehicle and attempt to reset the code or duplicate the previous complaint.
6. Check for fault codes using ServiceRanger.
 - If no fault codes set and vehicle operates properly, test complete.
 - If Fault Code 63 sets Active during the test drive, return to transmission specific diagnostic manual for extended trouble shooting.
 - If a fault code other than 63 sets, troubleshoot using appropriate troubleshooting manual.

Pre-Authorized Warranty Repair Guideline RWRG0078

Warranty Parts

- K-4223RX: X-Y Shifter
- P/N Varies: Transmission Harness

Warranty Labor

- Diagnostics - 0.3 hr
- Software Update if not current version - 0.5 hr
- SRT Transmission Harness R&R
- SRT X-Y Shifter R&R
- Road Test - 0.5 hr

Warranty Coding

- Part: A-7856
- Complaint: STUCK IN GEAR
- Failure: ROOT CAUSE NOT DETERMINED

Warranty Claim Filing

File pre-authorized warranty claim through appropriate OEM or through Direct Pay.

- RWRG0078
- OEM Warranty Coverage
- Software Revision (from and to)
- XY Shifter and Transmission Harness Kit used

Filing through Direct Pay

Click here for Direct Pay submission guidelines and claim forms:



Parts Disposition

Return Parts per OEM or Direct Pay guidelines.

Warranty Disclaimer

If the failure is not the result of an accident, damage, negligence, abuse or misuse, improper installation or maintenance or any other conditions described in the Limits and Exclusions section of the Eaton Warranty Manual TCWY0600, then Eaton will treat the condition as covered under its warranty. However, this conclusion does not necessarily mean that a defect in fact exists. In all cases, Eaton shall make the final determination and interpretation as to the warrantability of the product.

