

Roadranger Warranty Repair Guideline RWRG0069

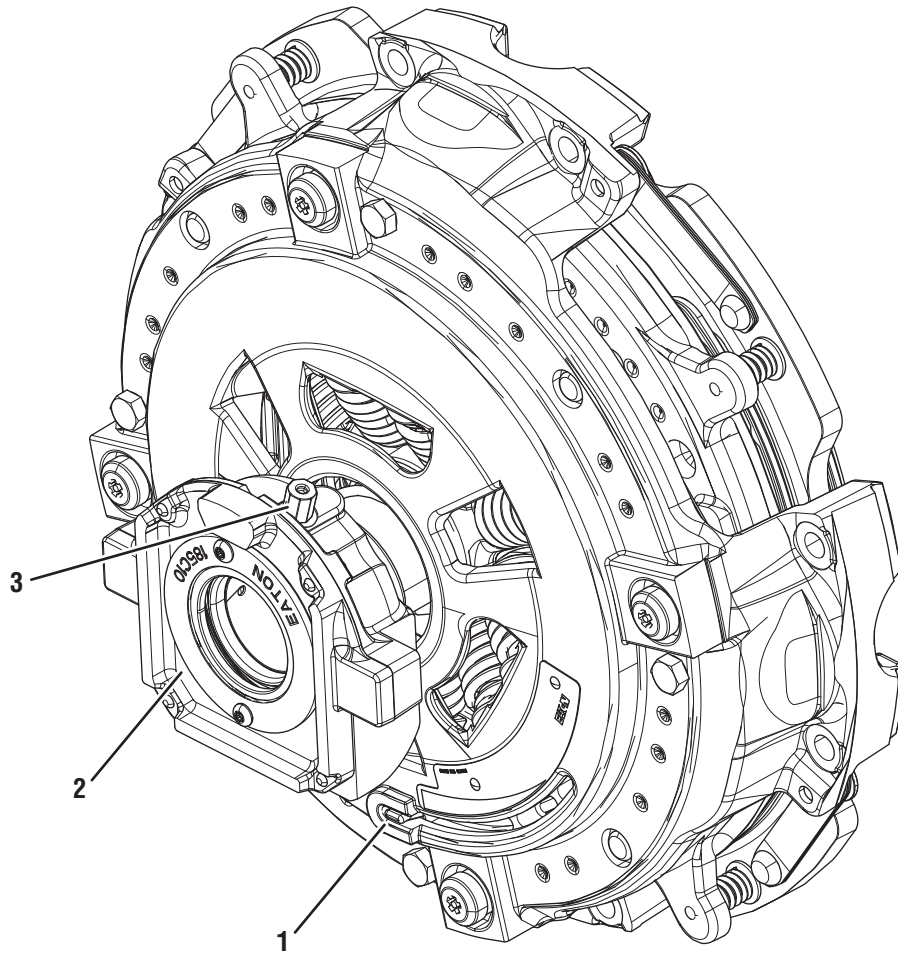

Eaton ECA Clutch

1. Clutch Wear Tab

2. Release Bearing

3. Release Bearing Grease Zerk

Fault Code 64 Troubleshooting and Repair Guidelines

A

Purpose: Identify ECA installed on transmission.

1. Inspect ECA OEM Power Supply Connector, reference image below.

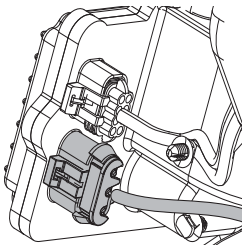

Gen1 ECA

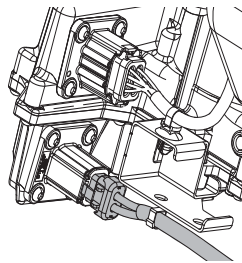

Gen2 ECA

- If equipped with a **Gen1 ECA**, Go to Step B.
- If equipped with a Gen2 ECA, troubleshoot active codes, refer to the appropriate Troubleshooting Guide on Roadranger.com. This Warranty Pre-Authorization **DOES NOT** apply to a Gen 2 ECA part.

B

Purpose: Check for Active or Inactive fault codes.

1. Record the transmission fault codes, FMIs, occurrences, and timestamps from the Service Activity Report created during the Diagnostic Procedure.
 - If Fault Code 64 is Inactive and there are other Active fault codes, troubleshoot active codes, refer to the appropriate Troubleshooting Guide on Roadranger.com. This Warranty Repair Guideline **DOES NOT** apply when other active codes are present and code 64 is inactive.
 - If Fault Codes 15, 16 or 19 is Active, troubleshoot active codes, refer to the appropriate Troubleshooting Guide on Roadranger.com. This Warranty Repair Guideline **DOES NOT** apply when these codes are present.
 - If Fault Code 64 is active or inactive and the scenarios above do not apply, **go to Step C**.

C

Purpose: Check fault code type.

1. Determine which FMI set for Fault Code 64, as noted in Step B.
 - If FMI 12 sets and no other fault codes are active, replace the ECA. **Go to Step V**.
 - If FMI 7 set, remove ECA and Inspect for clutch damage or failure. If no issues found, replace ECA. **Go to Step V**.

V

Purpose: Verify repair.

1. Key off.
2. Reconnect all connectors and verify that all components are properly installed.
3. Key on.
4. Clear fault codes using ServiceRanger.
5. Drive vehicle and attempt to reset the code or duplicate the previous complaint.
6. Check for fault codes using ServiceRanger.
 - If no codes set and the vehicle operates properly, test complete.
 - If Fault Code 64 sets active during the test drive, Perform 1 clutch adjustment and reattempt.
 - If a fault code other than 64 sets, troubleshoot using appropriate troubleshooting manual.

Roadranger Warranty Repair Guideline RWRG0069

Warranty Parts

- K-4252: Gen 2 ECA, includes adapter harness to OEM power supply and shield.

Warranty Labor

- ECA R&R SRT – 0.7 hrs
- Pull Codes and Send Service Activity Report – 0.3 hr
- Software, if required – 0.5 hr
- Road test repair confirmation –0.5 hrs

Warranty Coding

- Part: 4306651 (Gen 1 ECA)
- Complaint: FAIL LIGHT FLASHING
- Failure: ROOT CAUSE NOT DETERMINED

Warranty Claim Filing

File Pre-Authorized warranty claim through appropriate OEM or through Direct Pay. Document in Warranty Claim text/notes:

- RWRG0069
- OEM Warranty Coverage
- Software Revision from and to

Filing through Direct Pay

Click here for Direct Pay submission guidelines and claim forms:



Parts Disposition

Return Parts per OEM or Direct Pay guidelines.

Warranty Disclaimer

If the failure is not the result of an accident, damage, negligence, abuse or misuse, improper installation or maintenance or any other conditions described in the Limits and Exclusions section of the Eaton Warranty Manual TCWY0600, then Eaton will treat the condition as covered under its warranty. However, this conclusion does not necessarily mean that a defect in fact exists. In all cases, Eaton shall make the final determination and interpretation as to the warrantability of the product.

