



Kit Installation Manual

**EG-3P Actuator Installation
on Detroit Diesel V-149 Engine**

Manual 54005 (Revision A)

WARNING—DANGER OF DEATH OR PERSONAL INJURY



WARNING—FOLLOW INSTRUCTIONS

Read this entire manual and all other publications pertaining to the work to be performed before installing, operating, or servicing this equipment. Practice all plant and safety instructions and precautions. Failure to follow instructions can cause personal injury and/or property damage.



WARNING—OUT-OF-DATE PUBLICATION

This publication may have been revised or updated since this copy was produced. To verify that you have the latest revision, be sure to check the Woodward website:

www.woodward.com/pubs/current.pdf

The revision level is shown at the bottom of the front cover after the publication number. The latest version of most publications is available at:

www.woodward.com/publications

If your publication is not there, please contact your customer service representative to get the latest copy.



WARNING—OVERSPEED PROTECTION

The engine, turbine, or other type of prime mover should be equipped with an overspeed shutdown device to protect against runaway or damage to the prime mover with possible personal injury, loss of life, or property damage.

The overspeed shutdown device must be totally independent of the prime mover control system. An overtemperature or overpressure shutdown device may also be needed for safety, as appropriate.



WARNING—PROPER USE

Any unauthorized modifications to or use of this equipment outside its specified mechanical, electrical, or other operating limits may cause personal injury and/or property damage, including damage to the equipment. Any such unauthorized modifications: (i) constitute "misuse" and/or "negligence" within the meaning of the product warranty thereby excluding warranty coverage for any resulting damage, and (ii) invalidate product certifications or listings.

CAUTION—POSSIBLE DAMAGE TO EQUIPMENT OR PROPERTY



CAUTION—BATTERY CHARGING

To prevent damage to a control system that uses an alternator or battery-charging device, make sure the charging device is turned off before disconnecting the battery from the system.



CAUTION—ELECTROSTATIC DISCHARGE

Electronic controls contain static-sensitive parts. Observe the following precautions to prevent damage to these parts.

- Discharge body static before handling the control (with power to the control turned off, contact a grounded surface and maintain contact while handling the control).
- Avoid all plastic, vinyl, and Styrofoam (except antistatic versions) around printed circuit boards.
- Do not touch the components or conductors on a printed circuit board with your hands or with conductive devices.

IMPORTANT DEFINITIONS

- A **WARNING** indicates a potentially hazardous situation which, if not avoided, could result in death or serious injury.
- A **CAUTION** indicates a potentially hazardous situation which, if not avoided, could result in damage to equipment or property.
- A **NOTE** provides other helpful information that does not fall under the warning or caution categories.

Woodward Governor Company reserves the right to update any portion of this publication at any time. Information provided by Woodward Governor Company is believed to be correct and reliable. However, no responsibility is assumed by Woodward Governor Company unless otherwise expressly undertaken.

© Woodward 1979
All Rights Reserved

EG-3P Actuator Installation on Detroit Diesel V-149 Engine

Introduction

These instructions are for the conversion from the Woodward SG governor to the Woodward EG-3P actuator.

For information about electric controls, see manuals:
25070, Electric Governor Installation Guide
82516, EG-3P Product Specification
82560, EG-3P Manual

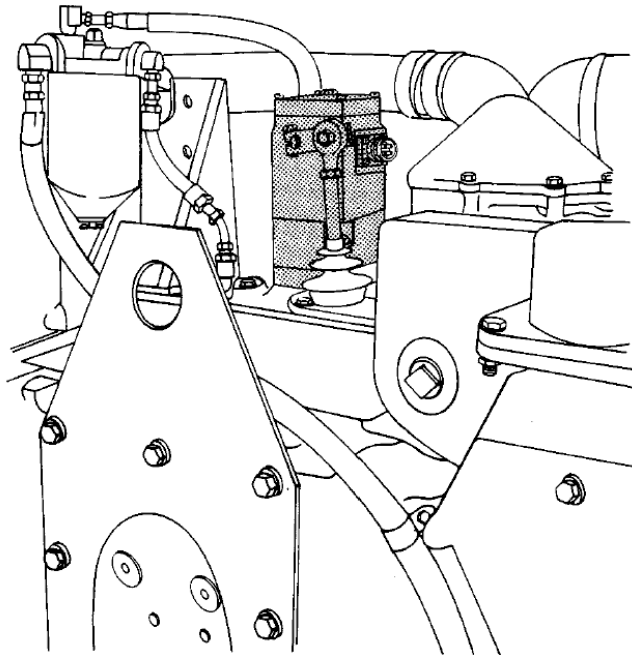

Parts List

The installation kit is for use on the Detroit Diesel V-149 engines with drives designed for the Woodward SG governor. The parts are sold in kit number 8956-142 which includes item 1 through 9. Items may be purchased separately.

When ordering replacement parts, give the following information.

- Manual Number 54005
- Part reference number, name of part, or description of part

Ref. No.	Part Name	Quantity
54005-1	Stud-Body	2
54005-2	Nut-0.312-24 Hex (.438 A/F)	2
54005-3	Washer -0.312 Helical Spring Lock	2
54005-4	Gasket - Drain Adapter.....	1
54005-5	Plate - Control Rod DDAD V-149	1
54005-6	Rod - 0.312-24 x 6.000 Connecting.....	1
54005-7	Screw - 0.312-24 x 1.750 Hex Head Cap ...	1
54005-8	Washer - 0.312 H. Collar Lock	2
54005-9	Spacer- 0.344 ID x 0.610 Long	1

**NOTE**

Items 10 through 20 are not made available by Woodward. They are normally included by the engine manufacturer as part of the SG governor installation arrangement.

Ref. No.	Part Name	Quantity
54005-10	Hex Head Screw	1
54005-11	Washer	1
54005-12	Lever - 0.82 Radius	1
54005-13	Rod End Size 5 R.H. Thread	1
54005-14	Jam Nut 0.312-24 RH. Thread.....	1
54005-15	Accordion Boot - Connecting Rod.....	1
54005-16	Jam Nut 0.312-24 LH. Thread	1
54005-17	Rod End - Size 5 L.H. thread.....	1
54005-18	Gasket - Control Rod Plate Assy.	1
54005-19	Bolt and Washer 1/4 - 20 x 1.000	1
54005-20	Bolt and Washer 1/4 - 20 x 0.750	2
54005-21	through 25 NUMBERS NOT USED	2

Optional Parts Available from Woodward

Ref. No.	Part Name	Quantity
54005-26	Kit - EG-3P Connector Assembly.....	1
Kit includes the following parts which may be ordered separately:		
54005-27	Plug - Elec Conn. Size 14.5 Straight.....	1
54005-28	Clamp - Cable MS 3057-6A	1
54005-29	Bushing - Cable Clamp MS 3420-6.....	1
54005-30-35	NUMBERS NOT USED	

Ref. No.	Part Name	Quantity
54005-36	Magnetic Pickup Assembly	1
Kit includes the following parts which may be ordered separately:		
54005-37	Plug - MS 3106-A 105-L-45	1
54005-38	Clamp - MS 3057-4A Cable	1
54005-39	Bushing - MS 3420-4 Cable Clamp.....	1
54005-40	Magnetic Pickup	1

Actuator Installation

See Figures 1 and 2 to install the EG-3P actuator on engine.

1. Remove the SG governor from engine.
2. Install two hold down studs (1) in the actuator pad.
3. Remove the SG control rod plate.
4. Install new control rod plate (5) (see Figure 2).
5. Install new connecting rod.(6)
6. Install the accordion boot.
7. Install drain adapter gasket (4) over hold down studs.
8. Install rod end (13) and spacer (9) on output lever (12).

9. Install the EG-3P on the engine.
10. Connecting linkage must move freely.
11. Install output lever (12) to the output shaft and adjust.
12. Install the oil line from the oil reservoir to either of two 1/8" pipe tapped inlet holes marked with an "S" on the base of the actuator. A minimum of 5 psi (34 kPa) oil supply pressure is needed. The supply should be filtered engine oil.
13. Include overspeed shutdown equipment separate from the speed control governor.

**NOTE**

Use approximately 21° actuator output shaft travel from no fuel to full fuel. Adjust the linkage so the maximum stop of the actuator will prevent the fuel rack from traveling beyond the full fuel position. The fuel injectors must move freely.

Magnetic Pickup Installation

1. Install the magnetic pickup in the flat surface used for the engine support bracket on the right side of engine. Drill an access hole in the engine support bracket and flywheel housing for the magnetic pickup. See Figure 3, Views A and B for location and dimensions of magnetic pickup hole.

The magnetic pickup is listed in the optional parts list.

2. The distance between the pickup and the outside diameter of the gear should be approximately 0.040" (1.02 mm) at the closest point. This clearance must be kept through one full turn of the flywheel.

**NOTE**

Find the distance by turning the magnetic pickup in until it just touches the gear tooth. Back it out about 3/4 turn (0.0555" [1.410 mm] per one 360° turn ccw).

3. Tighten the jam nut. Be careful not to turn the magnetic pickup.

Figure 1, Views A and B shows the linkage arrangement and reference numbers. Figure 1, View C, shows the new control rod plate. Figure 2 shows the control rod plate in relation to the EG-3P actuator. Figure 3 shows the location of the magnetic pickup and dimensions for drill and tap. Figure 4 shows the connector assembly. Figure 5 shows the magnetic pickup assembly.

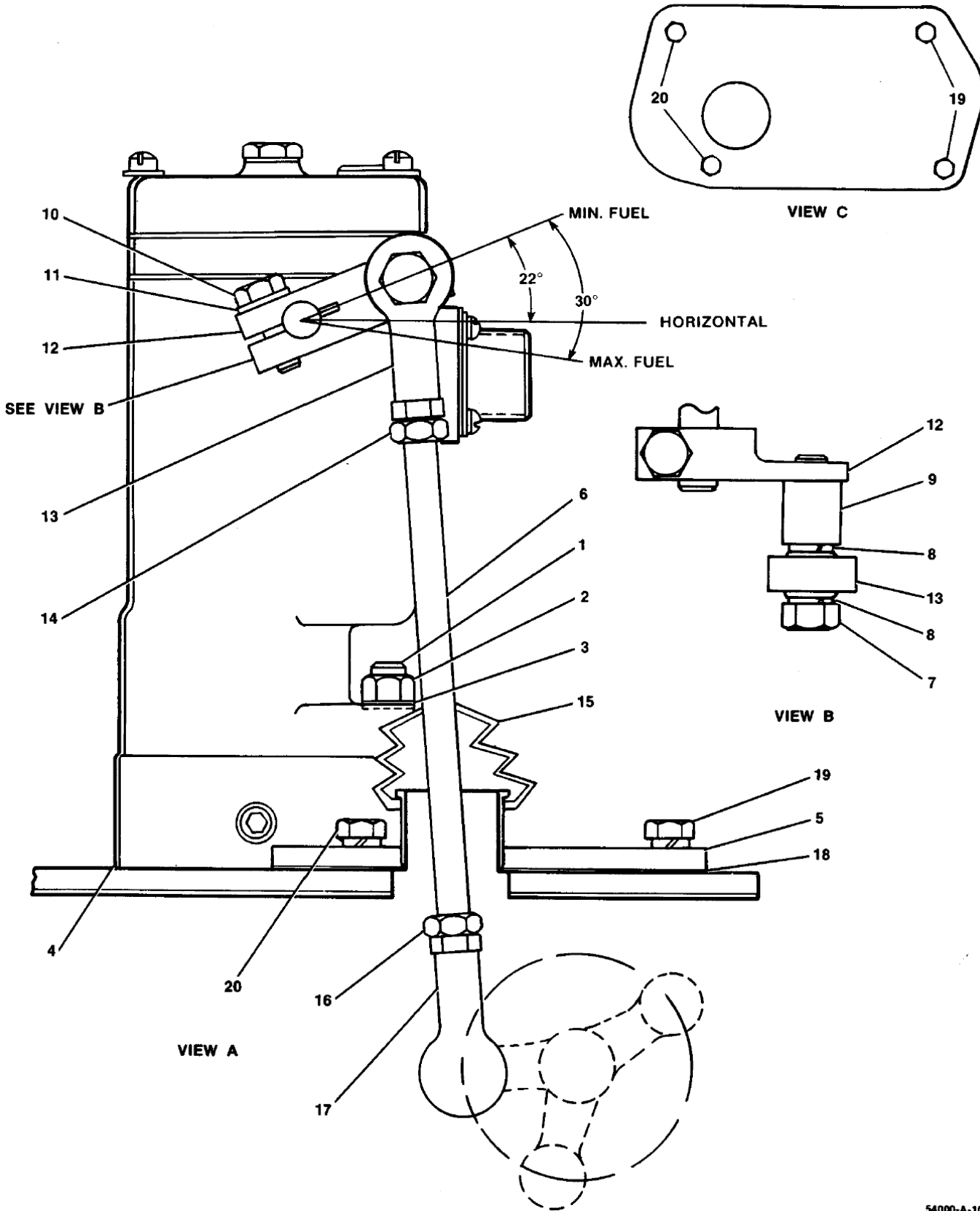

54000-A-10

Figure 1. Linkage Arrangement

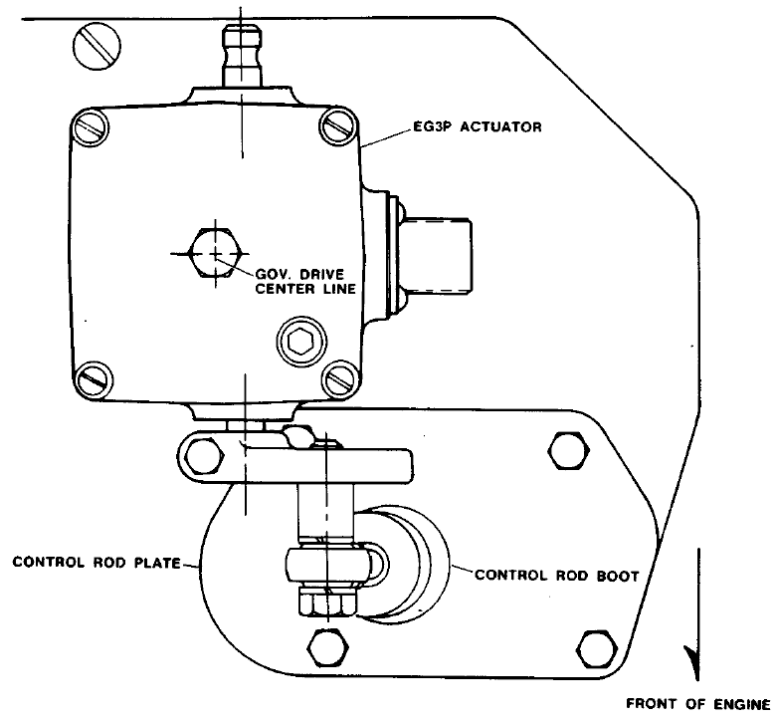

Figure 2. View of Control Rod Plate in Relation to EG-3P Actuator

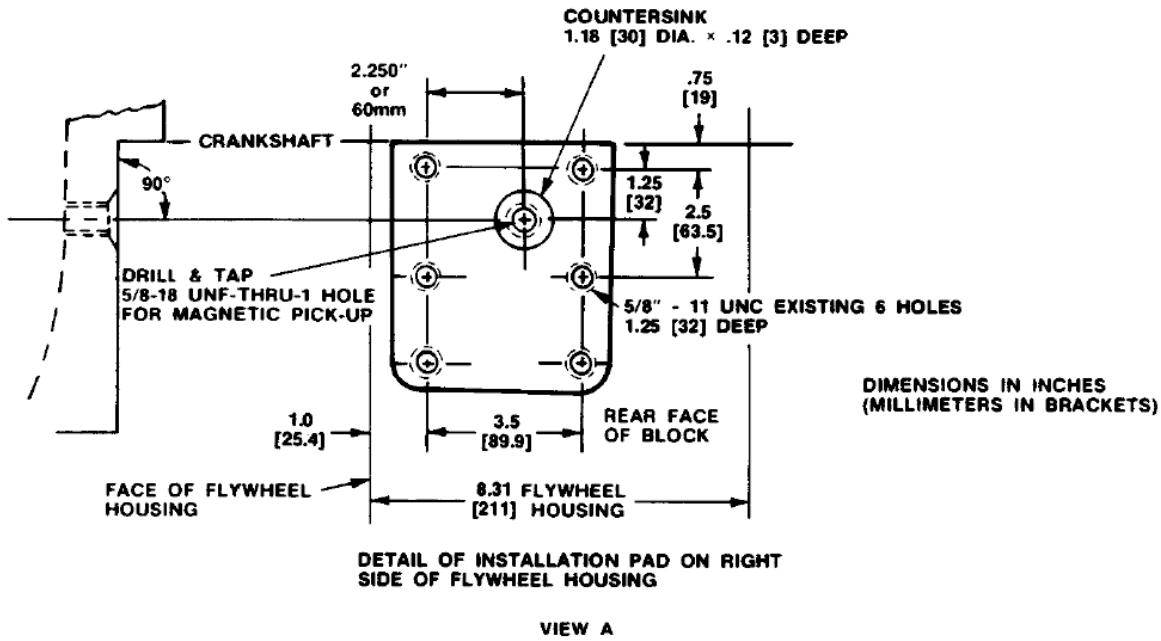

ILLUSTRATION OF ENGINE SHOWING INSTALLATION BRACKET

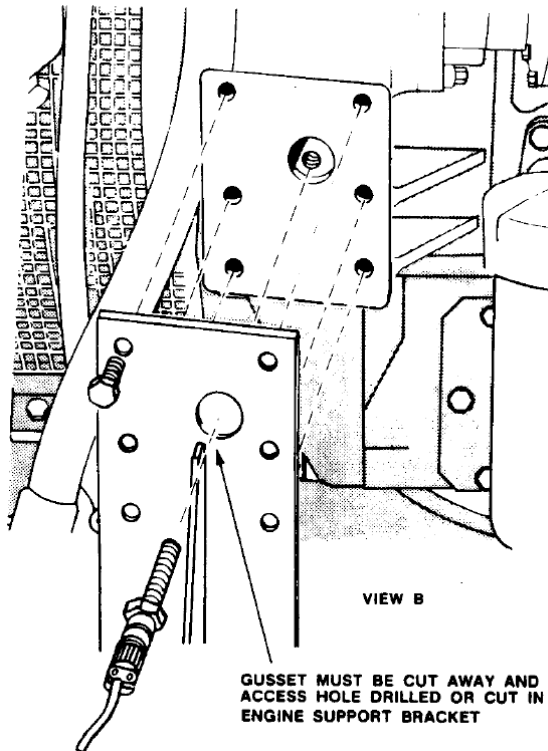

Figure 3. Magnetic Pickup Installation
(location of magnetic pickup in installation pad on right side of flywheel housing)

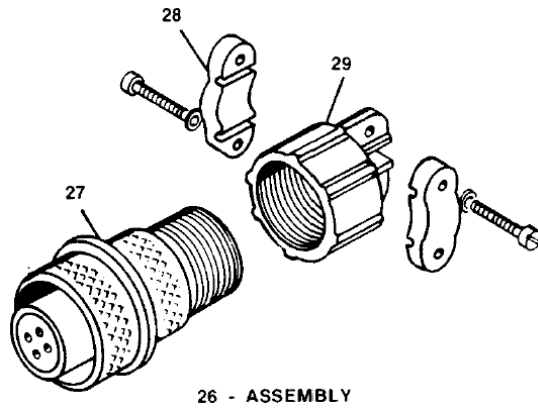
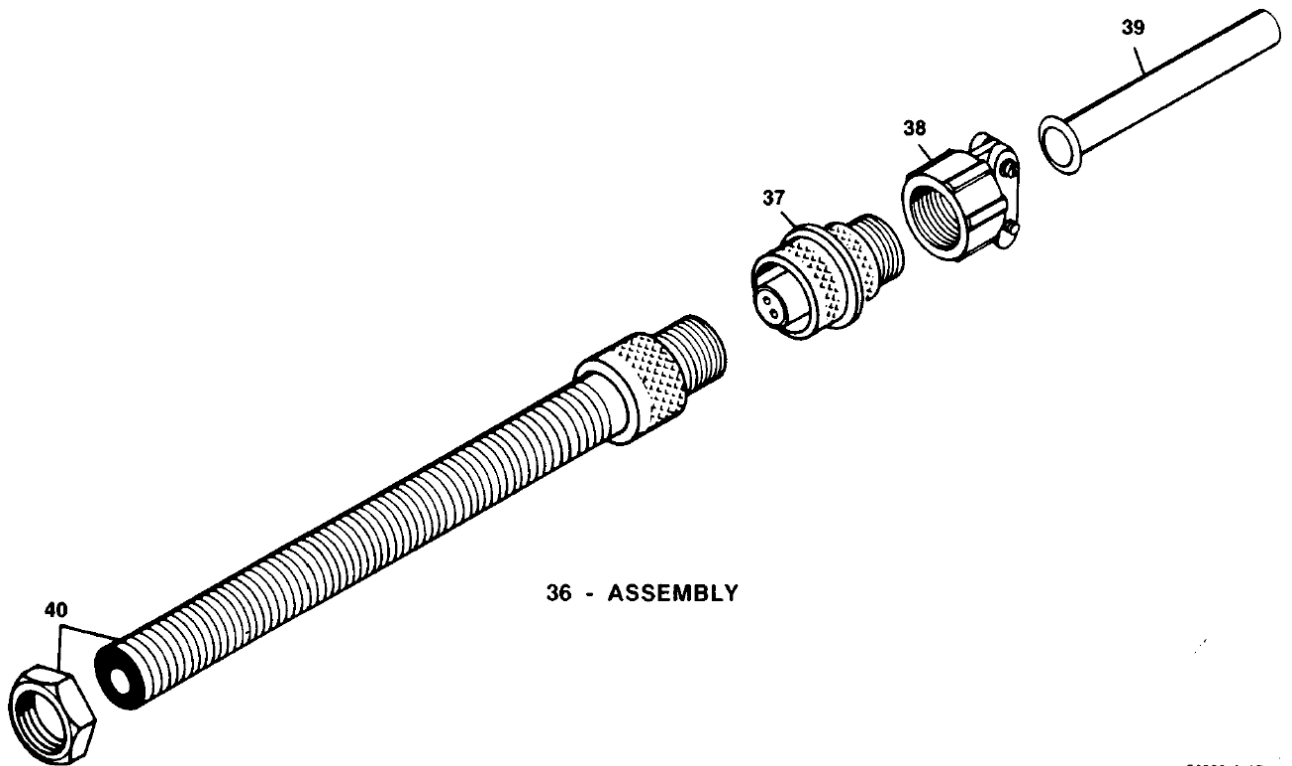

Figure 4. EG-3P Connector Assembly



54000-A-17

Figure 5. Magnetic Pickup Assembly

We appreciate your comments about the content of our publications.

Send comments to: icinfo@woodward.com

Please include the manual number from the front cover of this publication.



PO Box 1519, Fort Collins CO 80522-1519, USA
1000 East Drake Road, Fort Collins CO 80525, USA
Phone +1 (970) 482-5811 • Fax +1 (970) 498-3058

Email and Website—www.woodward.com

**Woodward has company-owned plants, subsidiaries, and branches,
as well as authorized distributors and other authorized service and sales facilities throughout the world.**

Complete address / phone / fax / email information for all locations is available on our website.